

Panasonic

DVCPRO P

Digital Camera/VTR

AJ-**PD900W**_P

Operating Instructions

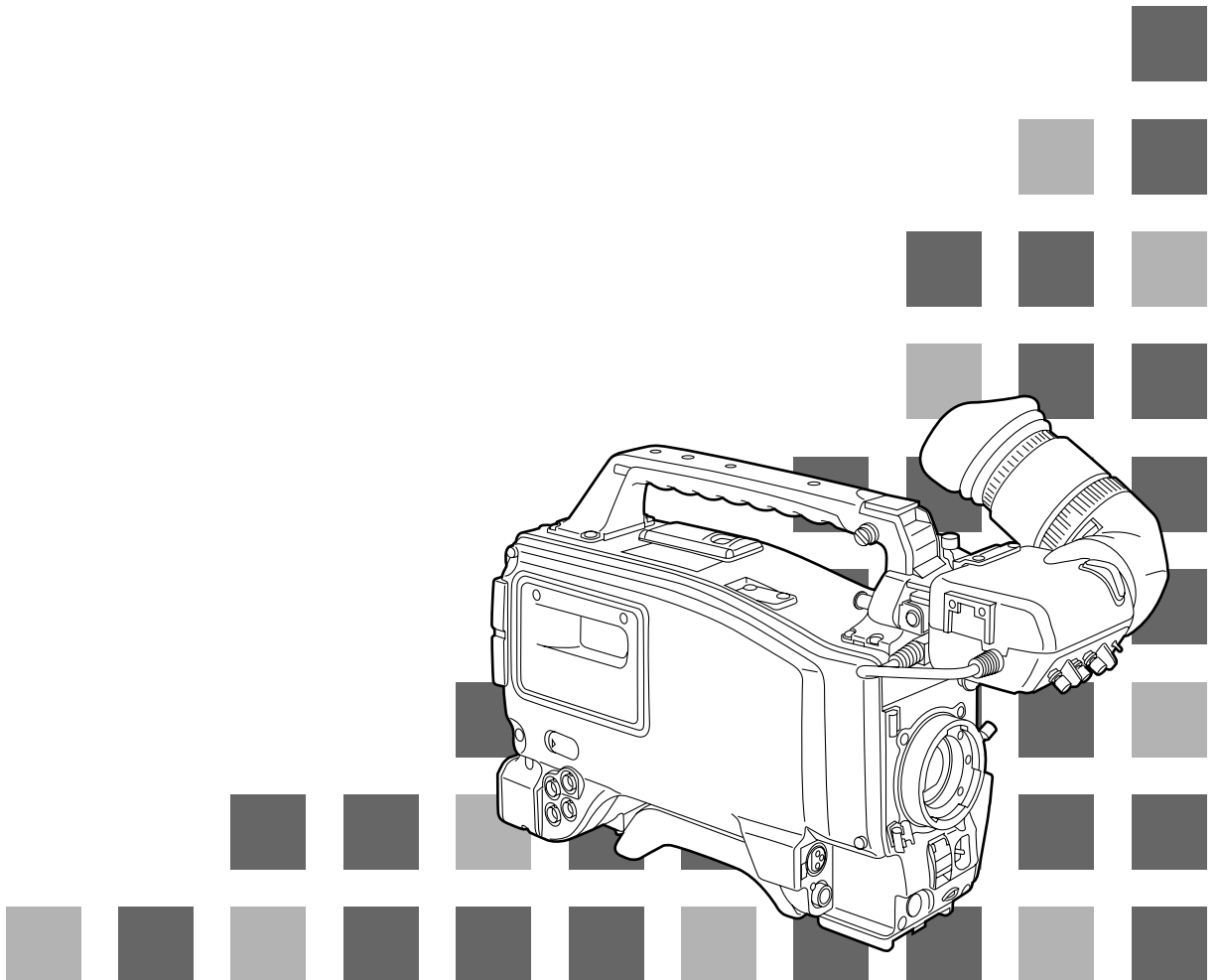

CAUTION RISK OF ELECTRIC SHOCK DO NOT OPEN	
CAUTION: TO REDUCE THE RISK OF ELECTRIC SHOCK, DO NOT REMOVE COVER (OR BACK). NO USER-SERVICEABLE PARTS INSIDE. REFER SERVICING TO QUALIFIED SERVICE PERSONNEL.	

The lightning flash with arrowhead symbol, within an equilateral triangle, is intended to alert the user to the presence of uninsulated “dangerous voltage” within the product’s enclosure that may be of sufficient magnitude to constitute a risk of electric shock to persons.



The exclamation point within an equilateral triangle is intended to alert the user to the presence of important operating and maintenance (service) instructions in the literature accompanying the appliance.

ATTENTION:

The product you have purchased is powered by a nickel cadmium battery which is recyclable. At the end of its useful life, under various state and local laws, it is illegal to dispose of this battery into your municipal waste stream.

Please call 1-800-8-BATTERY for information on how to recycle this battery.

ATTENTION:

Le produit que vous avez acheté est alimenté par une pile au nickel-cadmium. La pile est recyclable. Pour obtenir des renseignements sur les façons de recycler cette pile, appeler au 1-800-8 BATTERY.

Memory Back-Up Battery

Replace battery with part No. CR2032 only. Use of another battery may present a risk of fire or explosion. Caution—Battery may explode if mistreated. Do not recharge, disassemble or dispose of in fire.

FCC NOTE:

This device complies with Part 15 of the FCC Rules. To assure continued compliance follow the attached installation instructions and do not make any unauthorized modifications.

This equipment has been tested and found to comply with the limits for a Class A digital device, pursuant to Part 15 of the FCC Rules. These limits are designed to provide reasonable protection against harmful interference when the equipment is operated in a commercial environment. This equipment generates, uses, and can radiate radio frequency energy and, if not installed and used in accordance with the instruction manual, may cause harmful interference to radio communications. Operation of this equipment in a residential area is likely to cause harmful interference in which case the user will be required to correct the interference at his own expense.

CAUTION:

TO REDUCE THE RISK OF FIRE OR SHOCK HAZARD AND ANNOYING INTERFERENCE, USE THE RECOMMENDED ACCESSORIES ONLY.

WARNING:

TO REDUCE THE RISK OF FIRE OR SHOCK HAZARD, DO NOT EXPOSE THIS EQUIPMENT TO RAIN OR MOISTURE.

Contents

Safety Precautions	2	Audio Input Preparations	
General and Features	5	●Using the Microphone Mounted to the Main Unit.	37
●Features of the Camera Section	5	●Using the AJ-MC700P Microphone Kit (Option) Mounted to the Main Unit	37
●Features of the VTR Section	8	●Mounting the AJ-MH700P Microphone Holder (Option)	38
●System Configuration	9	●Using the Microphone not Mounted to the Main Unit.	39
Controls and Their Functions		●Mounting a Wireless Microphone	41
●Power Supply Section	10	Connecting an Audio Component	41
●Accessory Mounting Section	11	Mounting the Unit to a Tripod	42
●Audio Function Section	12	Mounting the Shoulder Belt	43
●Shooting (Recording)/Playback Function Section	14	Adjusting the Shoulder Pad Position	44
●Menu Operation Section	20	Attaching the Rain Cover	45
●Time Code-Related Section	20	Connecting the AQ-EC1 Extension Control Unit (Option)	46
●Warning/Status Display Section	22	Warning/Status Displays in the Viewfinder and Display Window	
Power Supply		●Displaying the Setting Menu Inside the Viewfinder	47
●Using an Anton Bauer Battery Pack	23	●Setting Menu Configuration	47
●Using the Panasonic AU-BP402 Battery Pack	24	●Basic Setting Menu Operations	49
●Using a Sony Battery Pack	26	Lamp Displays Inside the Viewfinder	51
●Using the Sony BP-90 Battery Pack	27	●Setting the ! Lamp Display	52
●Using the Sony BP-L60/BP-L90 lithium-ion Battery Pack	27	Status Displays Inside the Viewfinder Screen	53
●Using an AC Power Supply (When Using the AJ-B75 AC Adaptor)	28	●Selecting Display Items.	56
Mounting the Lens	29	●Display Mode and Setting Change Message	57
Adjusting the Lens Flange	30	●Changing the Display Mode	58
Adjusting the White Shading	31	●Setting the Marker Displays	58
Adjusting the Viewfinder		●Setting the Camera ID	59
●Adjusting the Position	33		
● Adjusting the Diopter and Screen	34		
●Adjusting the Eyecup Position	34		
●Detaching the Eyecup.	35		
●Detaching and Mounting the Viewfinder	36		

Bold letters should be set or adjusted immediately after purchase.

Contents

Displays		Playback—Checking Recorded Contents	
●Remaining Battery Level and Audio		●Rec Review	94
Level Displays	60	●Color Playback	94
●VTR Section Operation/Status-Related		Connection With an External VTR	95
Displays	60	Recording Simultaneously with the	
●Time Code-Related Displays	61	Internal VTR and an External	
Adjusting the Time and Date	62	VTR	96
Adjustments and Setup During Recording		Recording With an External VTR Instead	
●Adjustments and Setup using the Setting		of the Internal VTR	
Menu	63	●Using the 26-pin/12-pin Output	
●Setting the Gain Selector Value	64	Adaptor	98
●Selecting Functions	65	RET Button	100
Adjusting the White Balance/Black Balance		Replacing the Backup Battery	101
●Adjusting the White Balance	66	Setting Menu Screens	102
●Adjusting the Black Balance	69	Warning System	125
Setting the Electronic Shutter		Emergency eject	127
●Shutter Modes	71	Error Codes	127
●Selecting the Shutter Mode/Speed	72	Maintenance	
●Setting the Synchro Scan Mode	73	●Condensation	128
●Changing the Shutter Speed/Mode		●Cleaning the Video Heads	128
Selection Range	74	●Cleaning the Viewfinder	128
Changing the Iris Automatic Adjustment		●Characteristic Phenomenon of CCD	
Reference Value	74	Cameras	128
Adjusting the Audio Level	75	Inspections Before Shooting	
Setting the Time Data		●Inspection Preparations	129
●Setting the Time Code	77	●Inspecting the Camera Section	129
●Setting the User Bit	78	●Inspecting the Viewfinder	130
●Locking the Time Code to an External		●Inspecting the Iris and Zoom	
Source	79	Functions	131
●External Lock Operation		●Inspecting the VTR Section	131
Procedure	80	Specifications	
Setup Card Operations		●General	133
●Setup Card Handling	81	●Camera Section	133
●Setup Card Data Operations	82	●Viewfinder	133
Cassettes		●VTR Section	134
●Inserting and Ejecting Cassettes	87	●Accessories	134
●Preventing Accidental Erasure	88	●Related Components	135
Recording			
●Basic Procedures	89		
●Successive Shooting	92		

General and Features

The AJ-PD900W combines a color video camera, which features a 520,000-pixel high-sensitivity M-FIT 3-CCD configuration and an on-chip lens, with a DVCPRO format VTR which in turn features the latest compression technology in a single unit.

In addition to the existing interlace signals (525i), progressive signals (525P) can also be recorded. Either 16:9 or 4:3 can be selected as the screen aspect ratio, and the rate at which the signals are recorded onto the VTR tape can be set to 50 Mbps for a higher picture quality or 25 Mbps for longer recording duration. (Six recording modes are available for selection.)

The AJ-PD900W is compact and light weight with low power consumption, and realizes the optimal functions and performance for an electronic news gathering (ENG) VTR-integrated camera such as high picture quality and sensitivity, mobility, dustproofing and dampproofing, etc. In addition, both the camera section and the VTR employ a digital signal processing system which further improves picture quality and realizes a system for controlling setting menu and subject data by using world standard memory cards.

Features of the Camera Section

The camera section of the AJ-PD900W has the following features.

- High sensitivity: 2000 lux (F8)
- High S/N ratio: 60 dB
- Ultra-low smear
- Ultra-low flare

Digital signal processing

Signal processing is digitized by a 36 MHz (typ.) 10-bit AD/DA converter. This improves picture quality, stability and reliability, and allows the viewfinder screen displays as well as numerous adjustment and setup items to be converted to menus.

Setting menu

The setting menu is displayed on the viewfinder screen, and controls the status displays, messages, marker displays, etc. Whether or not to display each item, as well as the display conditions when items are to be displayed, can be selected according to the user's convenience. For example, display ON/OFF for the ! lamp display which informs the user that the unit has entered irregular status can be selected for 6 different conditions.

The setting menu is also used to select various settings and functions and execute memory card operations, etc.

Setup cards

Setting menu and subject data can be stored on SRAM memory cards with a capacity of 64 kilobytes or greater which conform to PCMCIA standard ratings as setup cards. Stored data can be saved individually or according to the shooting conditions, allowing the same setup conditions to be easily reproduced and assisting in standardizing setup conditions between individual data.

High-function electronic shutter

Using the built-in electronic shutter achieves steady images even of quickly moving subjects. In addition, the following special operation modes can also be selected.

- Synchro scan mode: This mode is suited for shooting personal computer and workstation monitor screens, and provides images with little horizontal stripe noise.

Wide range of video gain selections

Gain values can be selected from -3 dB to $+30$ dB using the setting menu and the GAIN switch. The high S/N ratio allows images with little noise to be obtained even when the gain is increased for shooting in dark locations. Using the SUPER GAIN switch provided specially to implement the super gain function, the video gain can be set to 30 dB.

Automatic adjustment and memory functions for black balance/white balance

The black set, black balance and white balance can be automatically adjusted by simple switch operations. Adjustment values are held in the memory even if the power for the unit is turned off, so there is no need to readjust the balance each time the power is turned on.

There are two memory systems for white balance which can hold four adjustment values each for the CC and ND filters, making a total of eight adjustment values. When adjustment values matching the illumination conditions are selected from among the values stored in the memory, the unit is automatically adjusted to the corresponding white balance. (A menu setting also allows adjustment of only two values instead of the values for each filter.) In addition, when the unit is shipped from the factory, the white balance value for 3200K is stored in the memory as a preset value. This value can be called when there is no time to adjust the white balance, etc.

High-performance viewfinder

- The high-resolution CRT projects a detailed picture which facilitates focus operations.
- The viewfinder employs a low flare CRT which makes the screen easy to see.
- A center marker which indicates the center of the screen and a safety zone marker which indicates the effective screen region can be displayed by menu operations.
- A large aperture allows the screen to be easily seen even when the operator's eye is removed from the eyepiece.
- The eyepiece can easily be detached. When the eyepiece is detached, the center of the screen will not become blurred even when viewed from a distance.
- One-touch position adjustment is possible not only in the right-left direction but also in the forward-backward direction.

Character display function

The unit is equipped with a function that displays switch settings, the automatic adjustment status for black balance and white balance, warning displays, etc. on the viewfinder screen. In addition, when using an Anton Bauer Digital Magnum series battery as the unit's power supply, the remaining battery level can be displayed numerically on the viewfinder screen.

Warning system for displaying the VTR section status

The unit informs of VTR trouble, the end of the tape, battery wear, etc. with various warning lamps and a warning tone. The remaining tape time can also be checked by the character display inside the viewfinder.

Four filter disks as standard equipment

CC (color temperature conversion) and ND (neutral density) filters are provided as standard equipment. This allows the optimal filter setting to be selected from among four combinations in accordance with the brightness of the subject.

Fine adjustment of the automatic iris reference value

The reference value for automatic iris adjustment can be finely adjusted by setting menu operations.

Auto close function

The unit is equipped with an auto close function which automatically closes the lens in the following cases.

- When the black balance is automatically adjusted.
- When the power is turned off in the auto iris mode.

Generation of SMPTE/SNG color bar and reference audio signals

The camera section contains a circuit which generates an SMPTE type color bar signal to facilitate color monitor adjustments, and a circuit which generates a reference level audio signal to facilitate audio level adjustments.

The unit also contains a circuit for generating SNG color bar signals which come in handy for sending signals to communication satellites.

Functions and circuits for assuring high picture quality

The AJ-PD900W is equipped with the following functions (and circuits) in order to assure high picture quality and is designed to make the fullest use of the advantages of the high-performance CCD.

- A built-in AUTO KNEE circuit achieves a wide dynamic range which allows large signals to pass through.
- A built-in 2-line image enhancer
- A built-in shading compensation function for use with a lens extender
- A built-in sawtooth wave generator for adjustments
- A zebra pattern ON/OFF selector switch which selects three types of zebra patterns including spot zebra from two levels of zebra patterns.

Audio functions

- A phantom power supply type super-cardioid microphone (option) can be attached and it can also be detached from the main unit for use in interviews.
- Microphone can also be connected, and can be attached to the main unit using the AJ-MH700P microphone holder (option).
- The audio CH1 recording level can be easily adjusted at the front panel of the unit.

Recording by an external VTR

When an external VTR is connected using the 26-pin/12-pin output adaptor (option, AJ-YA900P), recording can be performed by the external VTR instead of the internal VTR.

Remote control

Connecting the Extension Control Unit (option, AQ-EC1) allows a portion of the camera section functions to be operated by remote control.

Features

Features of the VTR section

Digital system

The VTR section features a component digital recording system that employs the latest compression technology and non-compressed PCM recording for audio. This system provides superior S/N, frequency band and waveform characteristics as well as reproduction of detailed areas, etc., and realizes even higher picture and sound quality.

One of the following 6 modes can be selected for conducting recording and playback: 16:9P (50 Mbps), 4:3P (50 Mbps), 16:9i (50 Mbps), 4:3i (50 Mbps), 16:9i (25 Mbps), 4:3i (25 Mbps).

Rec review function

This function automatically rewinds the tape and plays back the last two seconds recorded, allowing recorded contents to be quickly checked.

Playback function

Playback pictures (black-and-white pictures) can be seen on the viewfinder screen. In addition, color playback pictures can be seen on a color monitor connected to the VIDEO OUT connector on the main unit.

Built-in time code generator/reader

Time code information can be recorded and played back on a dedicated subcode track.

Locking of the time code to an external source

The built-in time code generator can be locked to an external generator. Also, the built-in time code generator uses a lithium battery as its back-up power supply, allowing time codes to be backed up for approximately one year even if power is not supplied to the unit.

Built-in DOLBY NR System*

A Dolby B Noise Reduction System is built in for audio recording in the longitudinal direction.

Successive shooting

Images can be shot successively within an accuracy of 0–+1 frame simply by pressing the VTR START button or the lens VTR button.

*Dolby noise reduction manufactured under license from Dolby Laboratories Licensing Corporation.

“Dolby” and the double-D symbol  are trademarks of Dolby Laboratories Licensing Corporation.

System Configuration

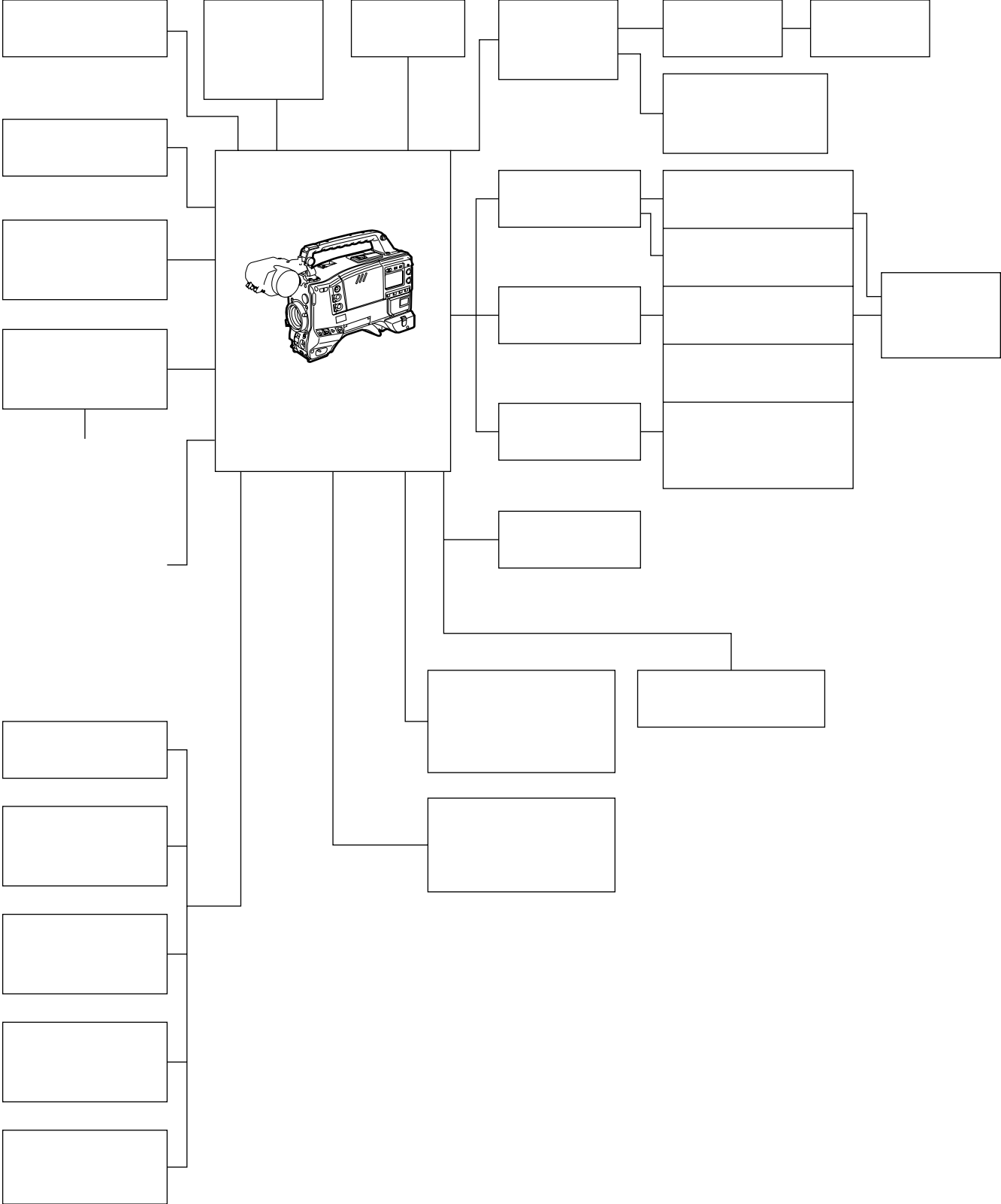

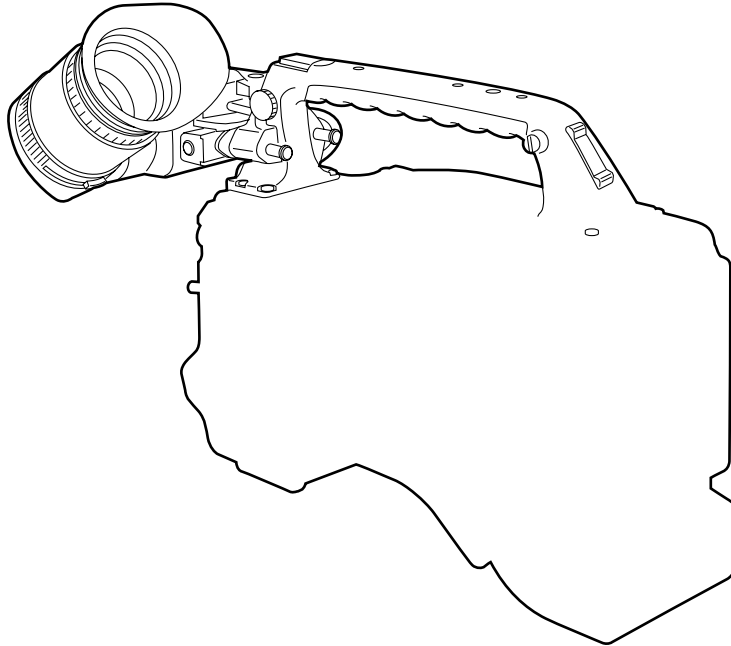

Power Supply Section

- e **Battery holder**
The battery pack (option) made by Anton Bauer is mounted onto this holder.
- f **DC IN (external power input) connector (XLR, 4P)**
The AJ-B75 AC adaptor (option) is plugged into this socket when the unit is to be operated by AC power. An external battery is plugged in when an external battery is to be used to operate the unit.
- g **BREAKER (circuit breaker) button**
In order to protect the equipment, the circuit breaker is tripped and the power is automatically turned off when an excessively high level of power flows inside. Upon completion of the internal inspection and adjustments, push this button back in. The power will come back on provided that there is no trouble inside the unit.
- h **POWER switch**
ON: Set to this position to turn on the unit's power.
OFF: Set to this position to turn off the unit's power.

Accessory Mounting Section

- i **Hook for mounting shoulder belt**
Attach the accessory shoulder belt to this hook.
- j **Light shoe**
Mount the video light, etc. onto this shoe.
- k **Lens mount (bayonet type)**
Mount the lens here.
- l **Lens clamping lever**
Insert the lens into the lens mount k , and turn the lens mount ring using this lever to clamp the lens.
- m **Lens mount cap**
Press up the lens clamping lever l to remove this cap. Keep the cap in place if the lens is not going to be mounted.
- n **Lens cable clamp**
This is for clamping the lens cable.
- o **Tripod mount**
When the unit is to be secured to a tripod, mount the optional tripod attachment.
- p **LENS connector (12-pin)**
Hook up the lens connecting cable to this connector. Consult with your dealer concerning the lens which you are going to use.
- q **Shoulder pad**
Adjust this pad to facilitate operation when carrying the unit on your shoulder. Its position can be brought forward or backward and adjusted by loosening the two set screws.

Audio Function Section (1)

- r **AUDIO LEVEL CH1 (audio channel 1 recording level) control**
When the AUDIO SELECT CH1/CH2 switch **u** is set to MAN, the recording level of audio channel 1 can be adjusted by this control in addition to the AUDIO LEVEL CH1 control **t** on the side panel.
- s **MIC IN (microphone input) jack (XLR, 3-pin)**
Connect an optional microphone to this jack. The power for the microphone is supplied from this jack.
- t **AUDIO LEVEL CH1/CH2 (audio channel 1/2 recording level) controls**
When the AUDIO SELECT CH1/CH2 switch **u** is set to MAN, the audio level of audio channels 1 and 2 can be adjusted using these controls.
However, the audio CH1 level can also be adjusted using the AUDIO LEVEL CH1 control **r** on the front panel.
- u **AUDIO SELECT CH1/CH2 switch (audio channel 1/2 auto/manual level adjustment selector) switch**
This selects the method used to adjust the audio levels of audio channels 1 and 2.
AUTO: For adjusting the levels automatically.
MAN: For adjusting the levels manually.
- v **AUDIO IN (audio input selector) switch**
This selects the input signals to be recorded on audio channels 1 and 2.
FRONT [MIC]: The microphone input signals connected to the MIC IN jack **s** are recorded.
REAR [MIC]: The microphone input signals connected to the AUDIO IN CH1/CH2 connectors **y** are recorded.
REAR [LINE]: The line input signals connected to the AUDIO IN CH1/CH2 connectors **y** are recorded.
- w **REAR MIC POWER switch**
ON: The phantom power is supplied to the rear microphone.
OFF: The phantom power is not supplied to the rear microphone.
- x **CUE switch**
CH1: The audio CH1 signals are recorded on the cue track.
1/2: The signals of audio CH1 and CH2 are mixed together and recorded on the cue track.
CH2: The audio CH2 signals are recorded on the cue track.
- y **AUDIO IN CH1/CH2 (audio input channel 1/2) connectors (XLR, 3P)**
An audio component or microphone is connected here.
- z **AUDIO OUT connector (XLR, 3P)**
This is connected to an audio component. The audio channels are coupled to the MONITOR SELECT switch **q** and switched in tandem.
- { **DC OUT (DC power output) connector**
This is the DC 12 V output connector. A current of approximately 100 mA can be taken out.

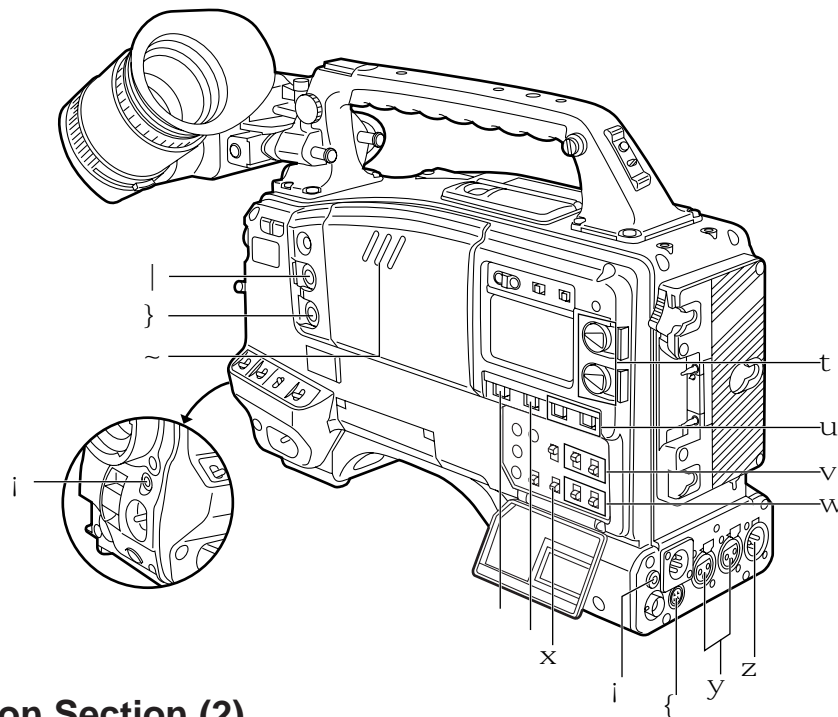

Audio Function Section (2)

| **ALARM (warning tone volume) control**

This adjusts the warning tone volume heard from the speaker ~ or the earphone connected to the PHONES jack i . When it is set to the lowest position, the warning tone is not audible. However, by making changes to the inside parts, the tone can be made audible even when the control is at its lowest position.

} **MONITOR (volume) control**

This adjusts the volume of the sound other than the warning tone—the sound from the speaker ~ or earphone i . When it is set to the lowest position, no sound is heard.

Audio Function Section (3)

~ **Speaker**

During recording, the EE sound can be monitored; during playback, the playback sound can be monitored.

The warning tone is heard through the speaker in synchronization with the flashing or lighting of the warning lamp and warning display.

The speaker sound is automatically muted when an earphone is connected to the PHONES jack i .

Ÿ **MONITOR SELECT (audio channel selector) switch**

This selects the audio channel whose sound is to be heard through the speaker ~ AUDIO OUT connector z , or earphone.

CH1: The audio channel 1 sound is output.

1/2: The sound produced by mixing the audio channel 1 and 2 sound or the stereo sound is output. However, only the mixed sound is output from the speaker ~ and AUDIO OUT connector z .

CH2: The audio channel 2 sound is output.

MONITOR (sound selector) switch

This selects the sound of the earphone when 1/2 is selected with the MONITOR SELECT switch Ÿ .

ST: The stereo sound of audio channels 1 and 2 is output.

MIX: The mixed sound of audio channels 1 and 2 is output.

i **PHONES (earphone) jack (mini-jack)**

When an earphone (option) is connected to this jack, the sound selected by the MONITOR switch can be heard. The warning tones relating to the unit's operation or status can also be heard. An earphone enabling a sufficiently high volume of sound to be heard is recommended.

When the earphone is connected, speaker ~ sound is automatically muted.

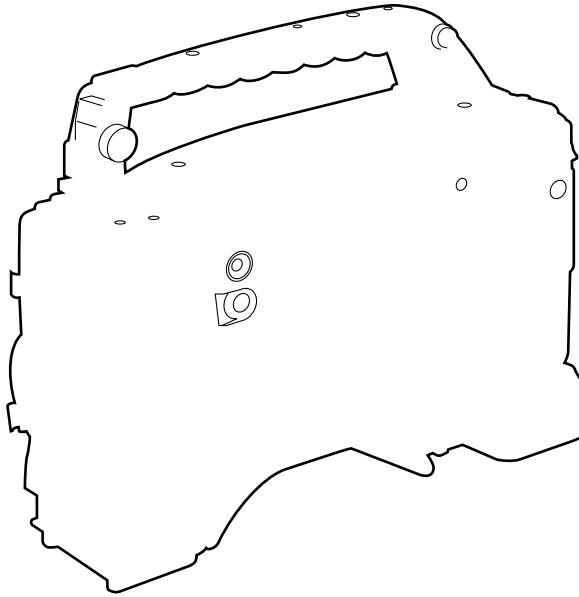

Shooting (Recording)/Playback Function Section (1)

- **Viewfinder**
Black-and-white images can be seen in the viewfinder during recording and playback. Warnings and messages relating to the unit's operating status and settings, zebra pattern, markers (safety zone marker, center marker), etc. can also be seen.
- £ **PEAKING control**
This is used to adjust the contours of the images inside the viewfinder to facilitate focusing. It does not affect the camera's output signals.
- / **CONTRAST control**
This is used to adjust the contrast of the screen inside the viewfinder. It does not affect the camera's output signals.
- ¥ **BRIGHT control**
This is used to adjust the brightness of the screen inside the viewfinder. It does not affect the camera's output signals.
- f **ZEBRA (zebra pattern) switch**
This displays the zebra pattern inside the viewfinder.
ON: The zebra pattern is displayed.
OFF: The zebra pattern is not displayed.
When the unit is shipped from the factory, the zebra pattern is set in such a way that those parts with an IRE video level from approx. 70% to 85% are displayed. The displaying of parts with a level ranging from 50% to 110% or more or with a certain level can also be set on the setting menu.
- § **Diopter control knob**
This is adjusted in such a way that the images on the viewfinder screen are seen most clearly in accordance with the dioptic power of the camera's operator.
- ⊠ **Eye cup**
- ' **Viewfinder forward-backward/left-right position clamp lever**
Loosen this lever to adjust the position of the viewfinder ◦ in the forward-backward or left-right direction.
- " **Eyecup forward-backward movement ring**
Turn this ring to adjust the position of the eyecup ⊠ in the forward-backward direction.
- « **Viewfinder stopper screw**
To detach the viewfinder ◦ from the camera, loosen this screw and then detach the viewfinder.

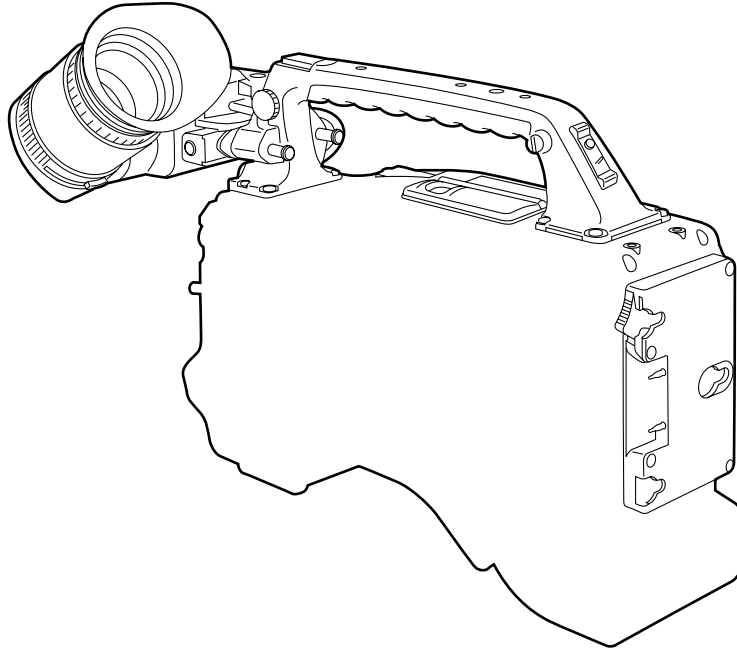

Shooting (Recording)/Playback Function Section (2)

< CC/ND FILTER (filter selector) knob

This selects the filter to match the light source which is illuminating the subject.

If the setting of this knob is changed when the menu display mode has been set to "3" (default setting), the new setting will appear for about 3 seconds on the setting change message display area of the viewfinder screen.

■ The knob and filter settings are listed below.

FILTER knob setting	Description
1	3200K
2	5600K+1/4ND
3	5600K
4	5600K+1/16ND

■ Examples of filter settings to match shooting conditions

Filter	Shooting condition
1	Sunrise, sunset, inside a studio
2	Outdoors under a clear sky
3	Outdoors under a cloudy or rainy sky
4	Snow scenes, high mountains, coastlines and other extremely clear and bright scenes

> Synchro scan adjustment switches

These switches are used to adjust the synchro scan speed. Pressing the "–" switch reduces the shutter speed; pressing the "+" switch increases the shutter speed. Set these switches to a position where the side bar noise in the viewfinder is eliminated during personal computer monitor shooting, etc.

f WHITE BAL (white balance memory selector) switch

PRST: Set to this position when there is no time to adjust the white balance. The white balance value for 3200K is stored in the memory.

A or B: When the AUTO W/B BAL switch – is pressed to the AWB side, the white balance is automatically adjusted in accordance with the setting position of the filter knob < , and the adjustment value is stored in memory A or memory B.

When the FILTER knob and the WHITE BAL switch are set to the same positions as the ones set when the adjustment was made, the adjustment value stored in the memory is called, and the unit is automatically adjusted to the white balance which corresponds to this value.

If the setting of this switch is changed when the menu display mode has been set to "3" (default setting), the new setting will appear for about 3 seconds at the WHITE BAL switch display position on the viewfinder screen. (Example: "W : A")

Controls and Their Functions

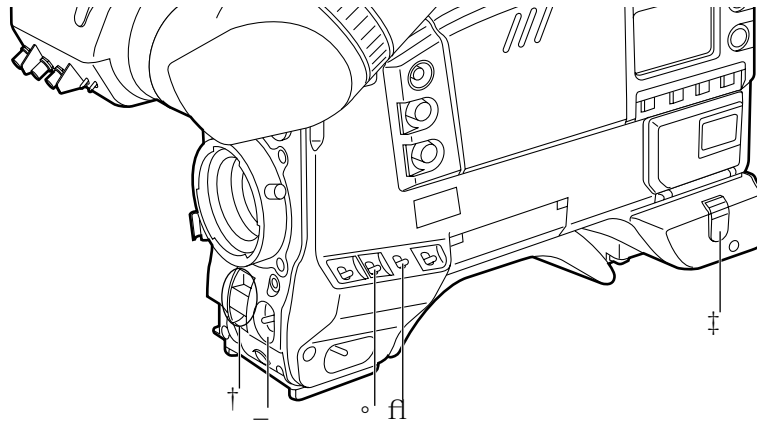

Shooting (Recording)/Playback Function Section (3)

fi OUTPUT (output signal selector)/AUTO KNEE switch

This switch selects the video signals which are to be output from the camera unit to the VTR unit, viewfinder and video monitor. The AUTO KNEE function can be used when the images shot by the camera have been selected.

■ OUTPUT/AUTO KNEE switch setting positions

BARS	Color bar signals are output. The AUTO KNEE circuit is not activated. Set the switch to this position in the following cases: <ul style="list-style-type: none"> ●When adjusting the video monitor ●When recording color bar signals
CAM, AUTO KNEE OFF	The images shot by the camera are output. The AUTO KNEE circuit is not activated. The default setting is "MANUAL KNEE".
CAM, AUTO KNEE ON	The images shot by the camera are output. The AUTO KNEE circuit is activated.

° GAIN (gain selector) switch

This is used to change the video amplifier's gain in accordance with the lighting conditions during shooting. The gain values corresponding to the L, M and H settings are assigned beforehand on the setting menu. When the unit is shipped from the factory, these settings are: L=0 dB, M=9 dB and H=18 dB.

If the setting of this switch is changed when the menu display mode has been set to "3", the new setting will appear for about 3 seconds at the gain display position on the viewfinder screen. (Example: "12 dB")

– AUTO W/B BAL (white balance/black balance automatic adjustment) switch

AWB: Set to this position for automatically adjusting the white balance. When the WHITE BAL switch fi is now set to "A or B", the adjusted value will be stored in memory A or memory B.

ABB: Set to this position for automatically adjusting the black balance. The adjusted value will be stored in the dedicated memory.

† SHUTTER switch

Set this to ON when using the electronic shutter. When it is pressed to the SEL side, the shutter speed and mode displays change in the ranges preset on the setting menu. If the setting of this switch is changed when the menu display mode has been set to "2" or "3", the new settings will appear for about 3 seconds at the shutter display position on the viewfinder screen. (Example: "1/201.9", "1/63.2")

1) AUTO KNEE function

When the level is adjusted to people, scenes, etc. for shooting against a very bright background, the background will be whited out and the buildings or scenes in the background will become blurred. If the AUTO KNEE function is activated in cases like these, the background can be reproduced in clear detail. This function is especially effective for shooting in the following conditions:

- When shooting people in shade under a clear sky
- When simultaneously shooting people in vehicles or indoor and the outdoor scenery seen through the windows
- When shooting scenes with a high contrast

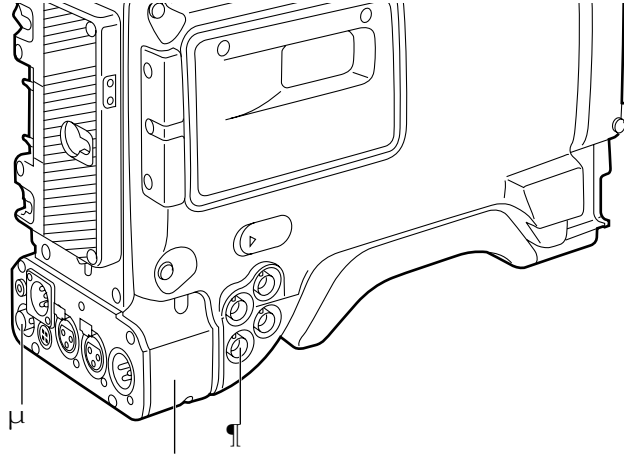

‡ **ECU REMOTE (remote control) connector (6-pin)**

Connect the AQ-EC1 extension control unit (option) here.

<Note>

The POWER switches on unit and extension control unit must be set to OFF before the remote control cable is connected or disconnected.

· **26-pin/12-pin output adaptor (option)** (See page 98 for mounting method.)

The 26-pin/12-pin output adaptor AJ-YA900P (option) is mounted on this section. When the portable VTR is connected as the external VTR, recording can be performed simultaneously with the unit's built-in VTR.

Furthermore, by connecting the SHAN-C12TCA multiconnector cable (optional accessory) to the 12-pin connector, it is possible to output the sound of audio channels 1 and 2 separately.

μ **VIDEO OUT connector (BNC)**

This outputs the video signals (75Ω termination, rated level) to be monitored. During recording, EE images can be monitored; during playback, playback images can be monitored.

While performing settings on the menu, the setting menu can be superimposed onto the shot images appearing on the monitor screen so that the settings can also be checked (in which case, the images appear in black and white).

¶ **CAM OUT (camera output) connector (BNC)**

This outputs the composite video signals (75Ω termination, rated level). When a video monitor is connected, the images shot by the camera can be monitored. Even while the VTR is playing back, the camera's images are output at all times.

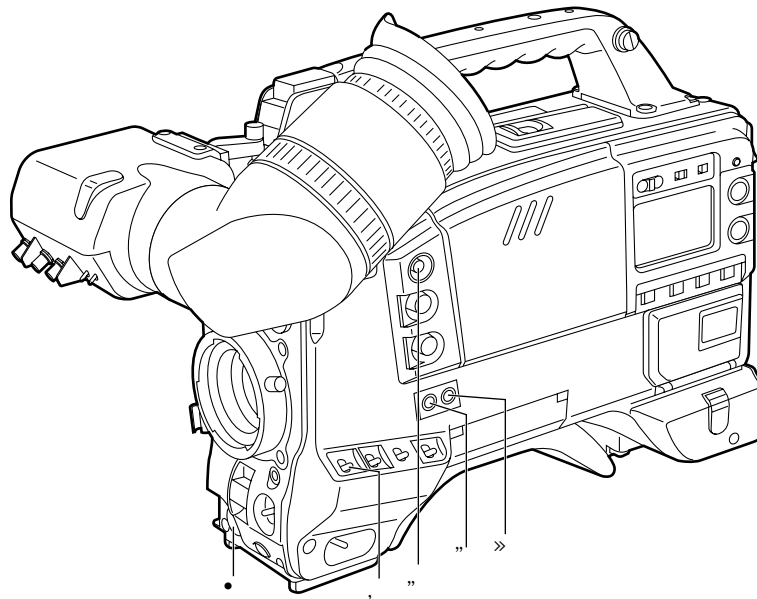

Shooting (Recording)/Playback Function Section (4)

- **VTR START button**
When this pressed, recording commences; when it is pressed again, recording stops. This button has the same function as the VTR button on the lens side.
- , **VTR SAVE/STBY (tape protection) switch**
This selects the power supply status while the VTR recording is temporarily stopped (REC PAUSE).
SAVE: This is the tape protection mode. The cylinder is stopped in the half-loading status. Compared with the STBY position, less power is consumed and the unit can be operated longer using the battery. It takes longer for recording to commence after the VTR START button • is pressed in the SAVE position than in the STBY position.
When the switch is set to this position, the VTR SAVE lamp inside the viewfinder lights.
STBY: Recording commences immediately when the VTR START button is pressed.
- ” **MODE CHECK button**
While this button is kept depressed, the camera's setting status is displayed in the viewfinder. It does not affect the camera's output signals.
- ” **SUPER GAIN button (inside sliding cover)**
Press this button to forcibly establish the super gain mode. Each time it is pressed, the gain is set in succession to 30 dB and OFF. When 30 dB is allotted to the SUPER GAIN button, DTL and other menu settings cannot be performed.
- » **SUPER IRIS button**
This is used when backlight compensation is to be provided. When it is pressed, the switch settings are displayed inside the viewfinder for 3 seconds. When it is pressed again, backlight compensation is released.

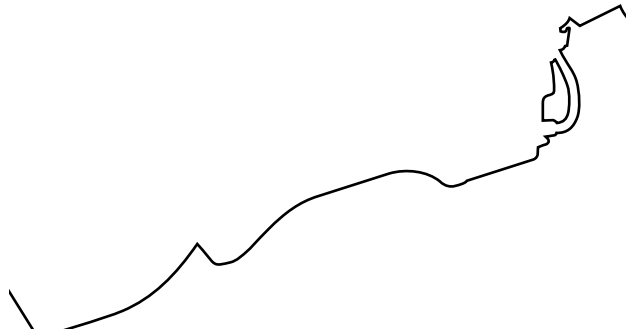
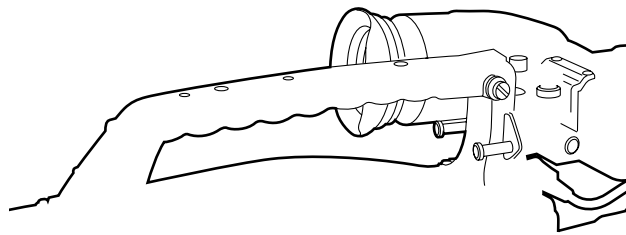

... **EJECT (cassette eject) button**

Press this to insert or eject the cassette.

‰ **REW (rewind) button**

Press this to rewind the tape. Its lamp lights during rewinding.

If this button is pressed during playback, the playback images are rewound at approximately quadruple speed while the button is held down.

¾ **FF (fast forward) button**

Press this to fast forward the tape. Its lamp lights during fast forwarding.

If this button is pressed during playback, the playback images are fast forwarded at approximately quadruple speed while the button is held down.

∞ **PLAY (playback) button**

Press this to view the playback images on the viewfinder screen or color video monitor. Its lamp lights during playback.

If this button is pressed again during playback, playback is paused and the lamp goes off. After playback has been paused for 2 minutes, the unit automatically switches to stop status (STOP).

∧ **STOP button**

Press this to stop the tape travel.

˘ **Emergency screw**

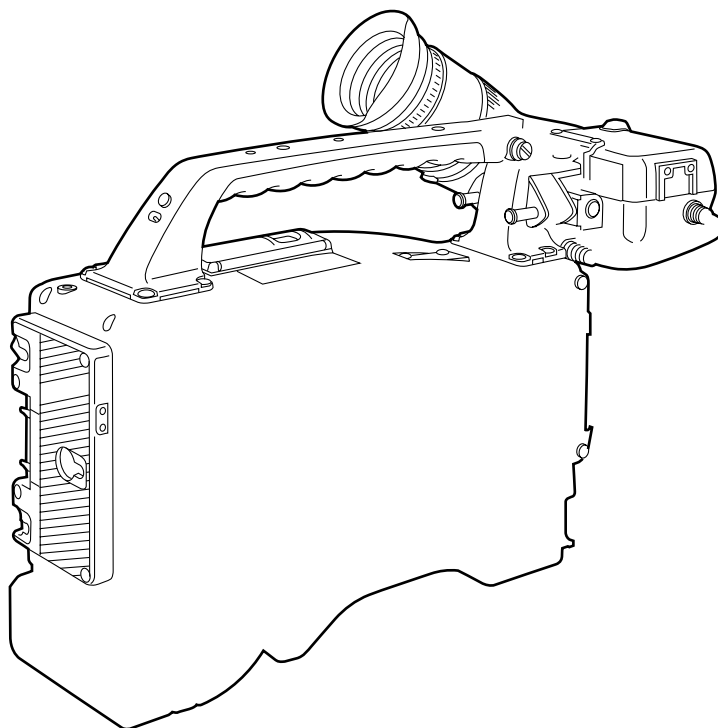

69 TC IN connector (BNC)

The time code serving as the reference is input when the time code is locked to an external source.

70 TC OUT connector (BNC)

Connect this to the time code TC IN connector on the external VTR when locking the external VTR's time code to this unit's time code.

Time Code-Related Section (2)

71 HOLD button

The time data appearing on the counter display at the instant when this button is pressed is held. (The time code generator will still continue to run.) When the button is pressed again, the hold status is released. Use the button to ascertain the time at which a particular scene was shot, for example.

72 RESET button

This resets the time data on the counter display to "00:00:00:00". When the TCG switch **76** is set to SET and this button is pressed, the time code or user's bit can be reset to "00:00:00:00" or "00 00 00 00".

73 DISPLAY switch

The time code, CTL or user's bit is made to appear on the counter display depending on the setting positions of this switch and the TCG switch **76**.

UB: The user's bit is displayed.

TC: The time code is displayed.

CTL: CTL is displayed.

74 UP button, DOWN button

When setting the time code or user's bit, these buttons increment or decrement by 1 the figure of the digit made to flash by the SHIFT/ITEM button **75**.

75 SHIFT/ITEM (digit advance) button

When setting the time code or user's bit, this button is used to cause the digit which is to be set to flash.

3 /

76 TCG (time code selector) switch

This is used to set the running mode of the internal time code generator.

F-RUN: This position is used when the time code is to be advanced continuously regardless of the VTR's operation.

Set to this position when aligning the time code with the actual time or locking the time code to an external source.

SET: This position is used for setting the time code or user's bit.

R-RUN: This position is used when the time code is to be advanced only while recording is in progress. The time code will be recorded continuously on a tape with a succession of unedited shots.

Warning/Status Display Section

77 Tally lamp

This is activated when the TALLY switch 78 is at HIGH or LOW, and it lights during recording by the VTR section. It flashes in the same way as the REC lamp inside the viewfinder to warn the operator. The brightness when lighted can be selected using the TALLY switch (HIGH or LOW).

78 TALLY switch

This controls the tally lamp 77.

HIGH: The tally lamp is made brighter.

OFF: The tally lamp is extinguished.

LOW: The tally lamp is made darker.

79 Back tally lamp

This functions in the same way as the tally lamp 77 when the back tally switch 80 is set to ON.

80 Back tally switch

This controls the back tally lamp 79.

ON: The back tally lamp operates.

OFF: The back tally lamp does not operate.

81 WARNING lamp

This flashes or lights when trouble occurs in the VTR section.

82 LIGHT switch

ON: This illuminates the display window 83.

OFF: This extinguishes the display window illumination.

83 Display window

The warnings related to the VTR section, remaining battery level, sound level, time data, etc. are displayed in this window.

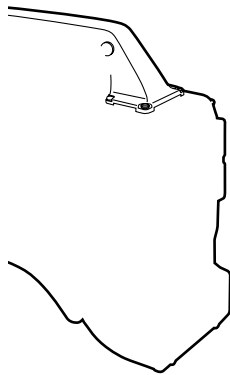

Power Supply

Using the Panasonic AU-BP402 Battery Pack

- 1 Detach the battery mounts.

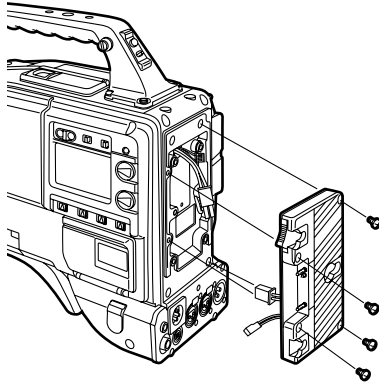

- 2 Connect the unit's connectors with the connectors of the AU-M402H battery case.

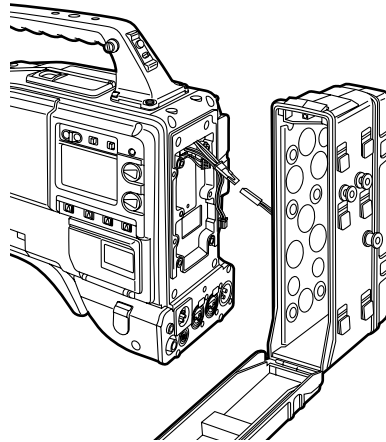

- 3 Mount the AU-M402H battery case.
Open the battery case cover and lift up the rubber cap to expose the screw holes. Tighten the screws with a screwdriver and mount the case to the unit. Be sure to tighten the screws completely.

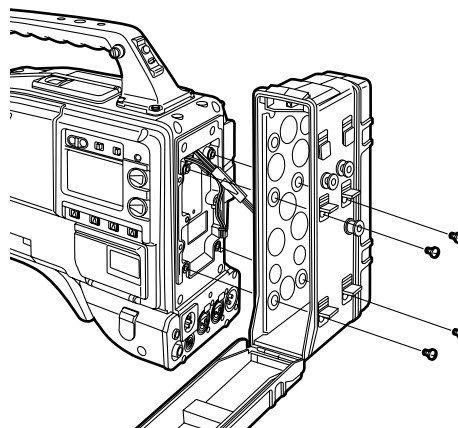

<Notes>

- Do not pull strongly on the rubber cap.
- Take care not to catch the connection cord between the battery case and the main unit.

-
- 4** Connect the battery pack plug to the connector inside the case and insert the battery pack.

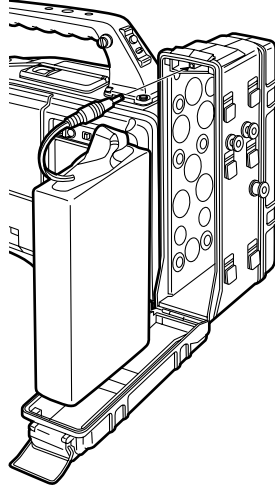

<Note>

The unit's power must be set to OFF before the plug is inserted or removed.

Power Supply

Using a Sony Battery Pack

- 1 Remove the battery mounts.
See page 24.
- 2 Mount the accessory battery mounting connector.

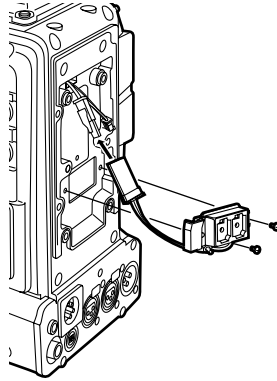

- 3 Mount the Sony battery holder.
Mount the battery case with the cover detached first, and then mount the detached cover as shown in the figure.
 - ① Tighten the mounting screws.
 - ② Tighten the power supply contact screws.
 - ③ Insert the top of the detached cover in the direction of the arrow.
 - ④ Align the hole at the bottom (metal part) of the cover with the hole at the bottom of the case and mount the cover to the battery mounting connector with the screw of the battery holder.

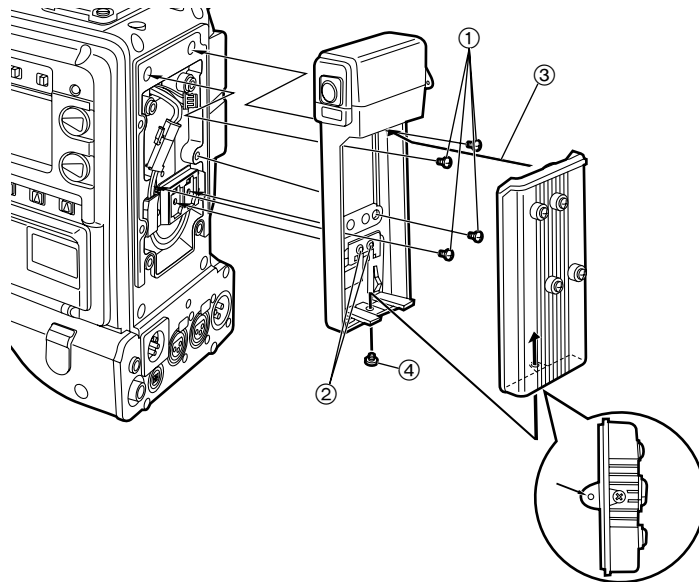

<Note>

Take care when attaching the battery holder that the wires are not pinched.

Using the Sony BP-90 Battery Pack

- 1** Mount the accessory battery mounting connector.
(See the preceding page.)
- 2** Mount the BP-90 battery case.
 - ① Tighten the mounting screws.
 - ② Tighten the power supply contact screws.
 - ③ Insert the top of the detached cover in the direction of the arrow.
 - ④ Align the hole at the bottom (metal part) of the cover with the bottom of the case and mount the cover to the battery mounting connector with the screw.

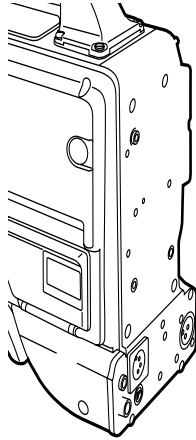

Using the Sony BP-L60/BP-L90 lithium-ion Battery Pack

- 1** Attach the supplied battery mounting terminals.
- 2** Attach the lithium-ion battery holder.
 - ① As shown in the figure, remove the battery clamp, and attach the holder using the mounting screws.
 - ② Tighten the power supply contact screws.
 - ③ Put the battery clamp back into place.

<Notes>

- The unit's power must be set to OFF before the plug is inserted or removed.
- Take care when attaching the battery case/battery holder that the wires are not pinched.

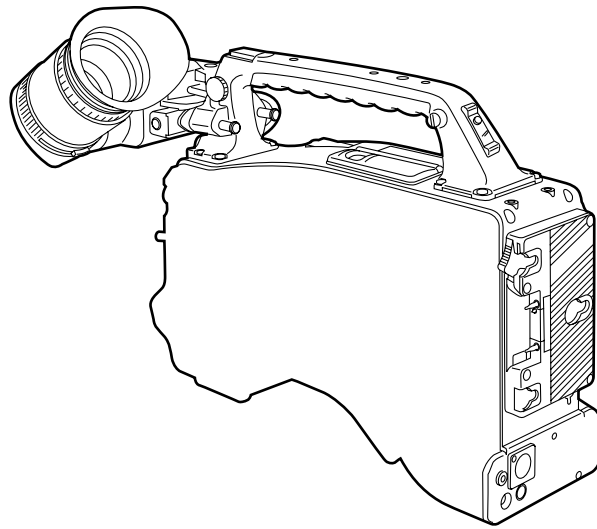

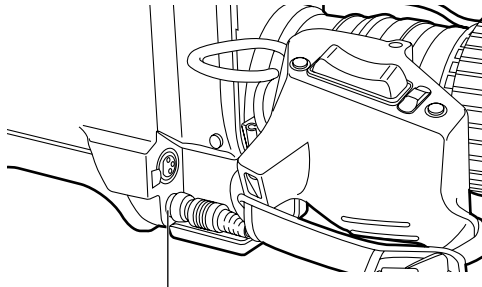
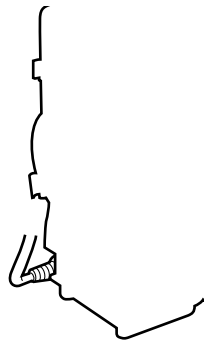

Adjusting the Lens Flange

When images are not clearly focused at both the telephoto and wide-angle positions during zoom operations, adjust the flange back (the distance from the lens mounting surface to the image formation surface).

Once adjusted, the flange back does not need to be readjusted as long as the lens is not changed.

Adjustment method

Check the position of each part of the lens which must be operated in order to adjust the flange back with the lens Handling Instructions.

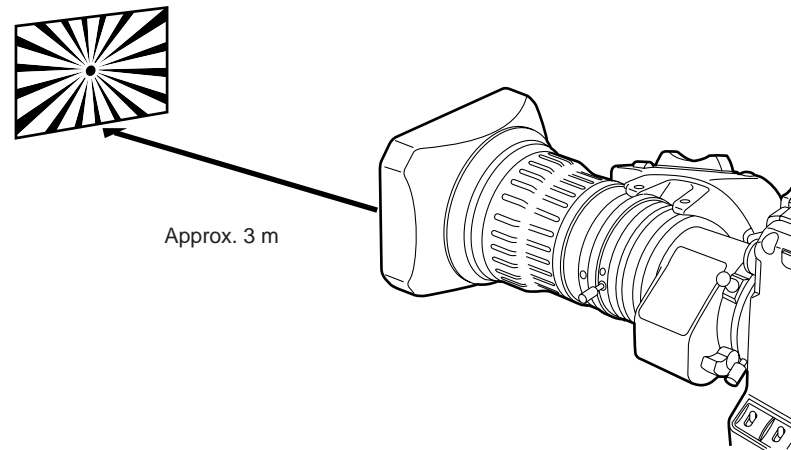

Adjusting the Flange Back

- 1** Set the lens iris to manual.
 - 2** Open the iris. Position the flange back adjustment chart about 3 m from the lens and illuminate it so that an appropriate image output level is obtained.
If the image level is too high, use the CC/ND filters or the shutter.
 - 3** Loosen the Ff ring clamping screw.
 - 4** Set the zoom ring to the telephoto position manually or by electric drive.
 - 5** Shoot the flange back adjustment chart and turn the distance ring to bring the chart into focus.
 - 6** Set the zoom ring to the wide-angle position.
 - 7** Turn the Ff ring to bring the chart into focus.
At this time, take care not to move the distance ring.
 - 8** Repeat this operation four to seven times until the lens is in focus at both the telephoto and wide-angle positions.
 - 9** Firmly tighten the Ff ring clamping screw.
- Refer to the Operating Instructions of the lens.

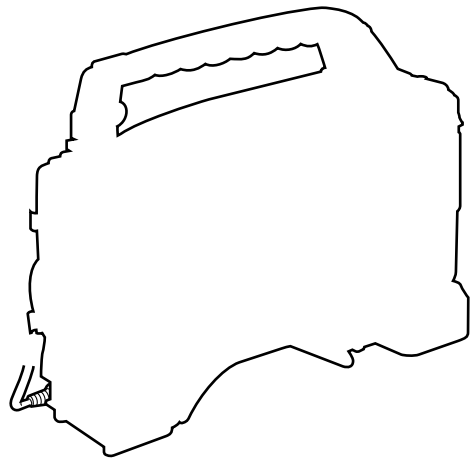

- 7** Set the WHITE BAL selector switch to A or B execute AWB.
Next, execute ABB and then execute AWB again.

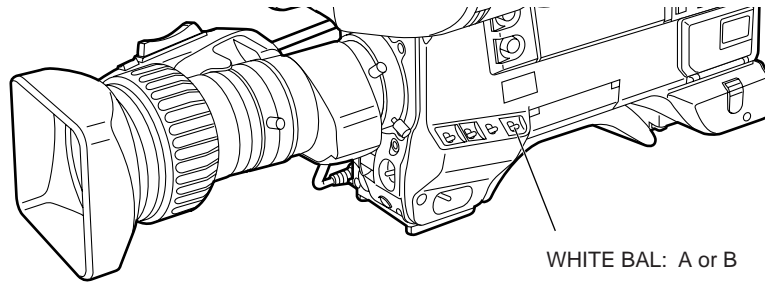

- 8** Repeat step 6.
- 9** Set the MENU switch from OFF to SET while holding down the SHIFT/ITEM and UP buttons to open the menu.
Press the PAGE button until the AUTO SHADING page appears.
Press the SHIFT/ITEM button to move the arrow on the left to the WHITE position and then press the UP or DOWN button.
ACTIVE appears on the viewfinder to indicate that white shading automatic adjustment is operating.
Adjustment is completed when the ACTIVE display disappears.
Return the MENU switch from SET to OFF to close the menu.

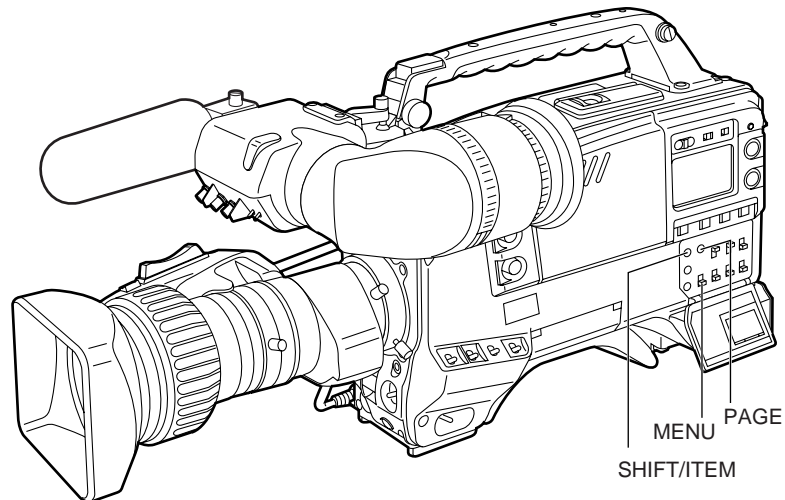

- 10** When the lens to be used has an extender, insert an extender and repeat steps 6 to 9.

This completes white shading adjustment.

The adjustment value is stored in the non-volatile memory, so there is no need to readjust the white shading even if the power for the unit is turned off.

<Notes>

1. The white shading can be adjusted for general lenses using the above method. However, this method may not apply for extremely special lenses.
2. Vertical coloring may occur near the open position of the lens iris even after performing the above adjustments. However, this is characteristic of the optical system of the lens, and does not indicate a malfunction.

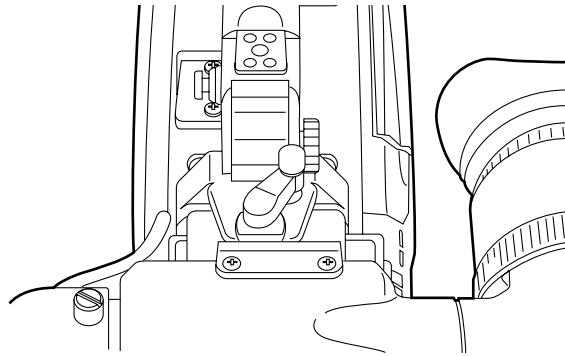

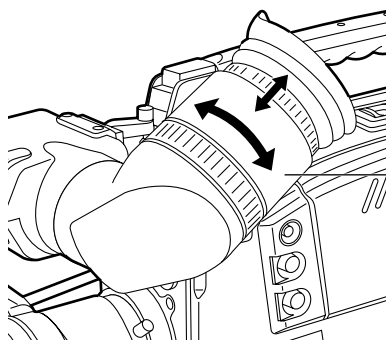
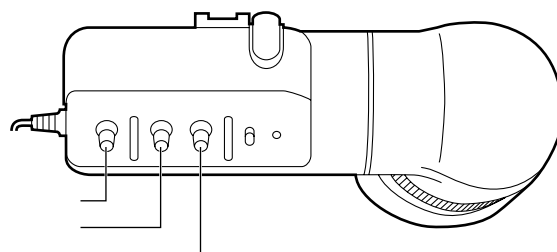

Detaching the Eyecup

Detaching the eyecup allows the entire screen to be seen clearly even when shooting with your eye removed from the viewfinder. This also facilitates the removal of dust which has adhered to the CRT screen and mirror.

<Note>

Absolutely do not wipe the mirror surface as it has been specially treated. Dust which has adhered to the mirror should be blown away with a blower, etc.

- 1** Press the lock button.
- 2** Turn the lock ring as far as possible in the counter-clockwise direction and line up the alignment marks on the lock ring and viewfinder barrel.

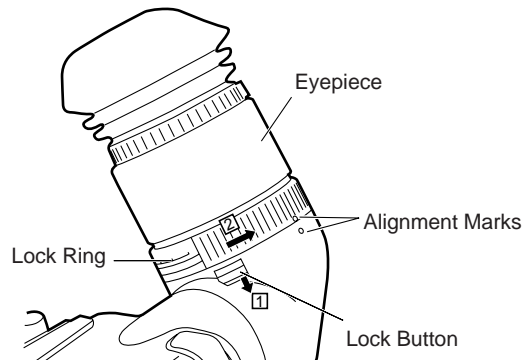

- 3** Detach the eyecup.



Remounting the eyecup

1. Line up the alignment marks on the lock ring and the viewfinder barrel, and then insert the eyepiece.
2. Turn the eyepiece as far as possible in the clockwise direction. The lock button latches with a clicking sound, and the remounting is completed.

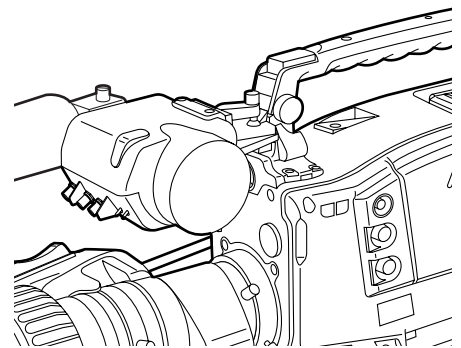

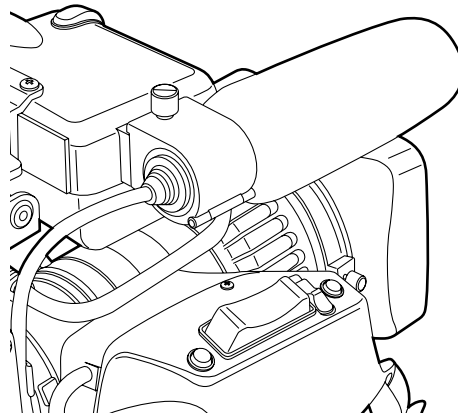
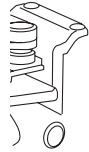

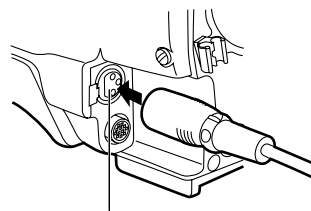

Using the Microphone not Mounted to the Main Unit

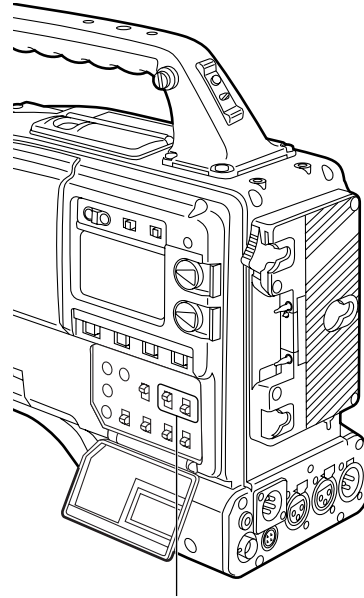
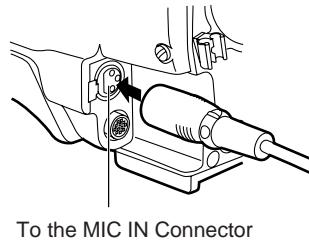

AUDIO IN switch: Set the AUDIO IN switch for the audio channel you wish to record to FRONT [MIC].

<Note>

When extending the microphone, use a cable which supports the phantom power supply type of microphone.

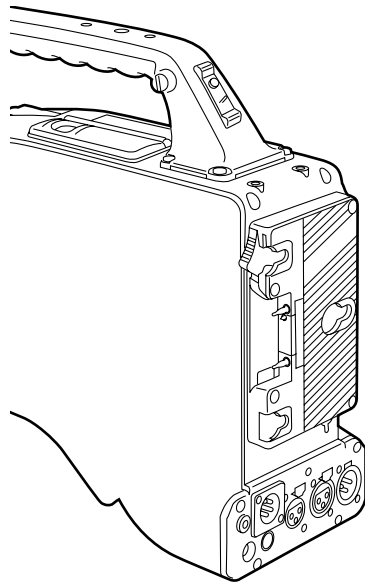

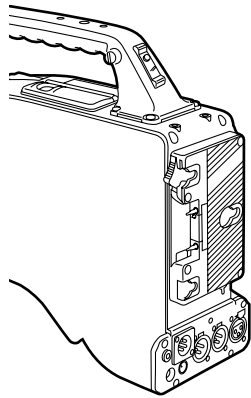

Mounting the Unit to a Tripod

When mounting the unit to a tripod, use an optional tripod attachment.

- 1** Mount the tripod attachment to the tripod.
Select the attachment hole in consideration of the unit's and tripod attachment's center of gravity. In addition, check that the diameter of the selected hole matches the diameter of the universal head's camera mounting screw.

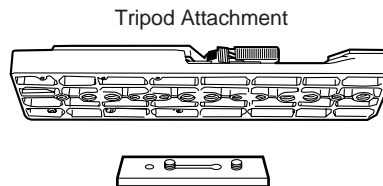

- 2** Mount the camera to the tripod attachment.
Slide the unit forward along the grooves until a clicking sound is heard.

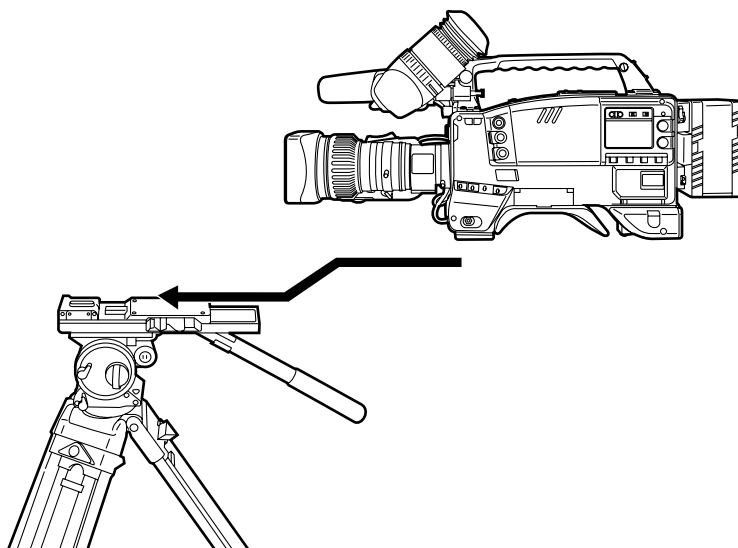

When detaching the tripod attachment

Hold down the red lever and move the black lever in the direction of the arrow.

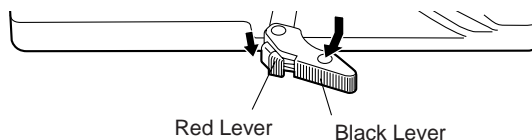

<Note>

When the tripod attachment pin does not return to its original position after the camera has been detached, hold down the red lever and move the black lever in the direction of the arrow again to return the pin to its original position.

Care should be taken as the camera cannot be mounted if the pin remains in the center.

Mounting the Shoulder Belt

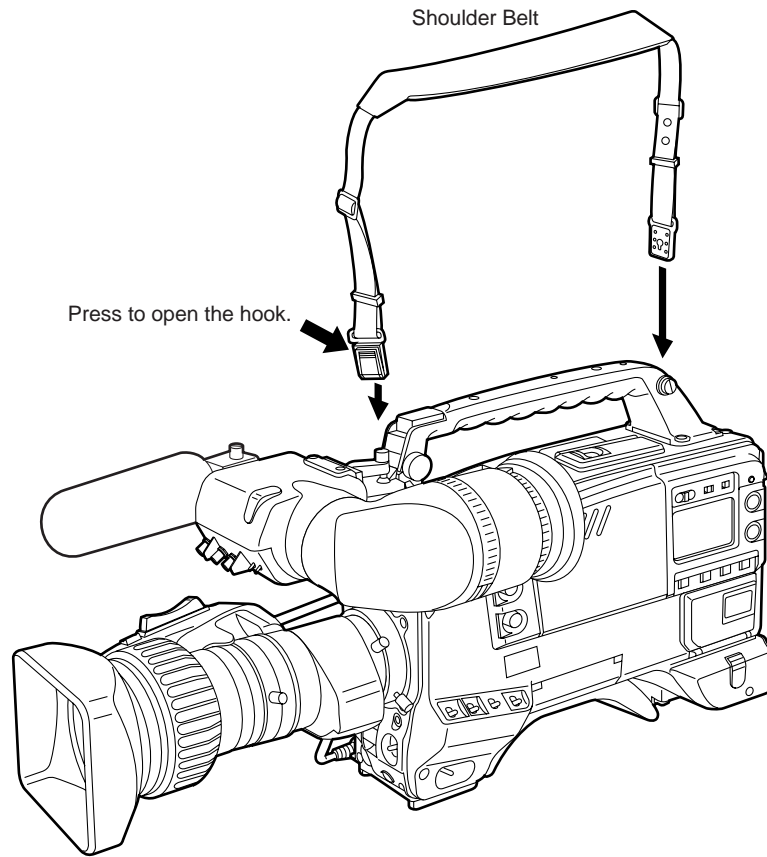

To remove the shoulder belt, open the hooks and then remove the belt.

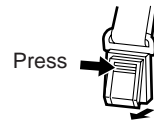

<Note>

When mounting and removing the shoulder belt, press on the top of the hooks to check that the belt is securely mounted.

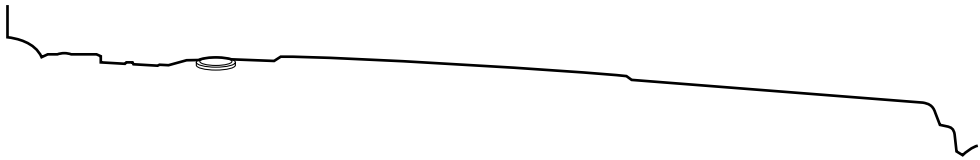

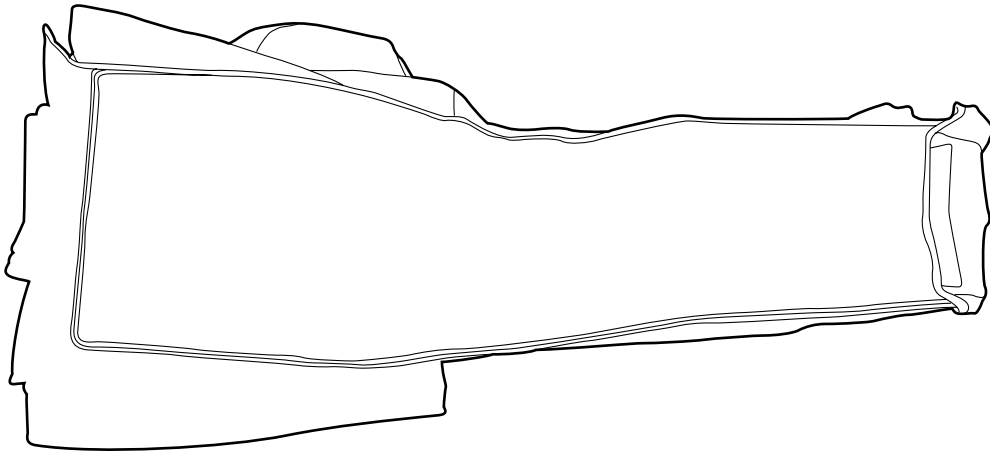

Connecting the AQ-EC1 Extension Control Unit (Option)

Connecting the AQ-EC1 extension control unit (option) allows a portion of the camera section functions to be operated by remote control.

When the AQ-EC1 is connected and the POWER switches of the unit and AQ-EC1 are set to ON, the unit automatically enters remote control mode.

The handling instructions included with the AQ-EC1 describe operations for when the AQ-EC1 is connected to an AQ series digital camera.

When the AQ-EC1 is connected to the AJ-PD900W, some functions differ, and some features cannot be used.

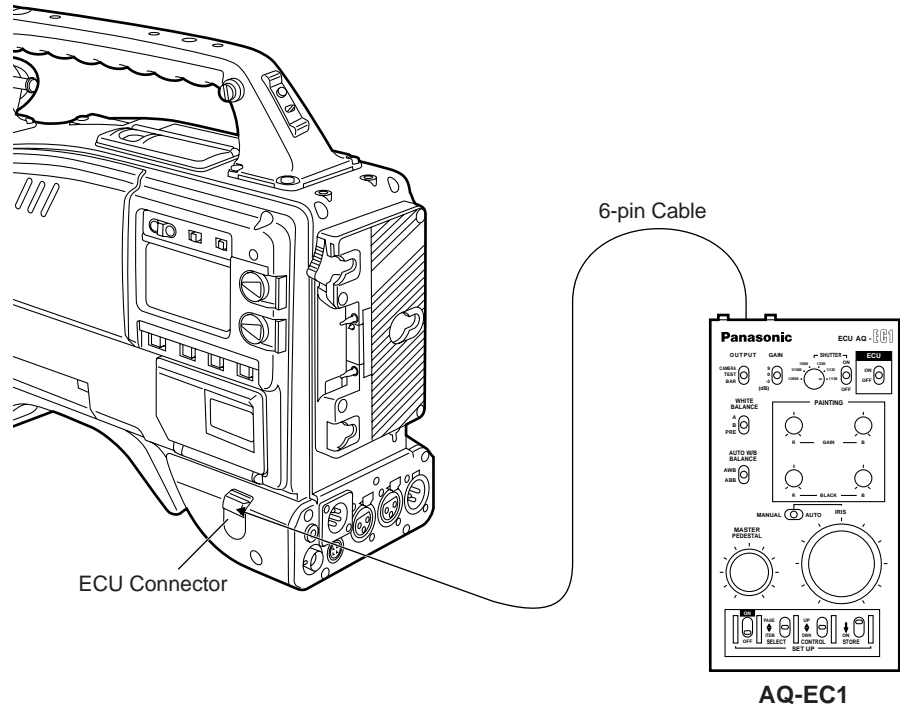

<Notes>

- The POWER switches of the unit and AQ-EC1 must be set to OFF before the 6-pin cable is connected or disconnected.
- All adjustments and settings made using the switches and controls other than the menu setting section of the AQ-EC1 are erased when the unit's POWER switch is set to OFF. Also, adjustments and settings made using the AQ-EC1 cannot be written to setup cards. However, when the AQ-EC1 is connected again, these settings return to the AQ-EC1 settings. (Menu contents set with the menu setting section are saved.)

<Note>

The functions of the AQ-EC1 are limited as follows.

- The STORE switch does not function. (If the menu settings are changed while the AQ-EC1 is connected to the AJ-PD900W, the new menu settings are saved automatically as soon as the changes are made.) Note that the AQ-EC1 gain switch displays -3, 0 and 9 correspond to L, M and H, and the OUTPUT switch settings CAMERA, TEST and BAR to CAM/AUTO KNEE ON, CAM/AUTO KNEE OFF and BAR for each main unit.
- The Synchro scan and Super V modes cannot be used while the AQ-EC1 is connected to the unit.
- The lens iris (IRIS) control of the AQ-EC1 is valid only when the lens iris AUTO/MANUAL selector is set to AUTO.

Warning/Status Displays in the Viewfinder and Display Window

Displaying the Setting Menu Inside the Viewfinder

When the MENU SET/OFF switch is set to SET, the setting menu appears on the viewfinder screen. The setting menu is displayed in page units. The following table lists all pages contained in the setting menu as well as an outline of the functions for each page.

The setting menu configuration can be changed according to the purpose.

Setting Menu Configuration

Page No.	Page name	Function outline	Reference
58	MARKER	Marker settings	Setting the Marker Displays
56	VF DISPLAY	Selection of viewfinder screen displays	Setting Display Items
59	CAMERA ID	Camera ID display settings	Setting the Camera ID Display
72	SHUTTER SPEED	Shutter speed/mode settings	Setting the Electronic Shutter
73	SYNCHRO SCAN	Synchro scan shutter speed settings	Setting the Electronic Shutter
52	! LED	! lamp display settings	Setting the ! Lamp Display
81	SET UP CARD	Setup card	Setup card operations
107	MAIN FUNCTION	Used function settings	—
107	BATT/TAPE ALARM	Selection of battery/tape end alarm	—
108–110	FUNCTION 1/5 to 5/5	Used function settings	Selecting Functions
62	TIME DATE	Time and date settings	Selecting Functions
64	SETTING LOW/MID/HIGH	Camera settings	Selecting Functions
115–119	LEVEL 1/6 to 6/6	Camera settings	Recording Adjustments
120	VF OPERATION	Viewfinder operations	Viewfinder
121	LENS ADJ	Lens adjustments	Lens
121–123	MENU SELECT 1/3 to 3/3	User menu ON/OFF settings	User Menu
124	AUTO SHADING	Automatic shading adjustments	Shading
50 124	DATA RESET	Resetting the setting menu	Returning to the default settings
124	DIAGNOSTIC	—	—

See the corresponding pages for a detailed description of each page's functions.

<Note>

When connecting the AQ-EC1 extension control unit (option) and controlling the AJ-PD900W externally, the engineer menu is always opened as the setting menu.

Warning/Status Displays in the Viewfinder and Display Window

Changing the setting menu configuration

The setting menu can be configured by selecting only the pages necessary for the application. Pages are selected using the MENU SELECT page of the engineer menu mode.

When using the engineer menu, switch the unit to engineer mode as described below.

The unit is switched to user mode by setting the MENU SET/OFF switch to "SET".

The unit is switched to engineer mode by holding down the SHIFT/ITEM and UP buttons simultaneously and setting the MENU SET/OFF switch to SET.

The user and engineer modes differ as follows.

User mode: Only the selected pages the setting menu can be used. The data set on each page is written to the non-volatile memory, allowing it to be stored for extended periods of time.

Engineer mode: All pages contained in the setting menu can be used. In addition, the data set at each page is written to the non-volatile memory, allowing it to be stored for extended periods of time.

After completing the adjustments and settings with engineer mode, configuring a menu consisting only of frequently used pages allows the necessary pages to be called quickly.

(The method is selected using the menu selections on pages 121 to 123.)

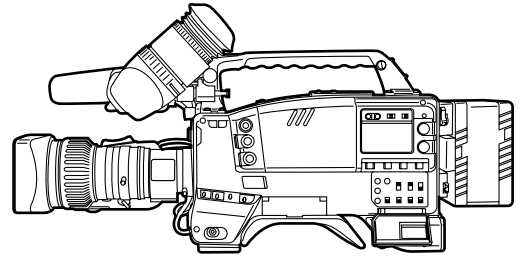
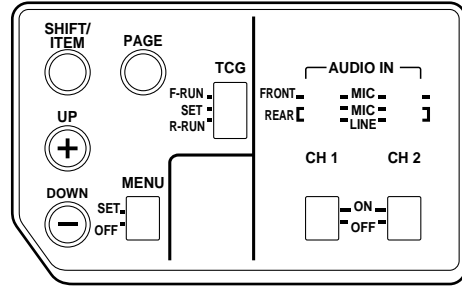

Warning/Status Displays in the Viewfinder and Display Window

Selecting the desired item

- 1 Press the SHIFT/ITEM switch.
Each time this button is pressed, the cursor (arrow) which indicates the selected item moves to the next item.

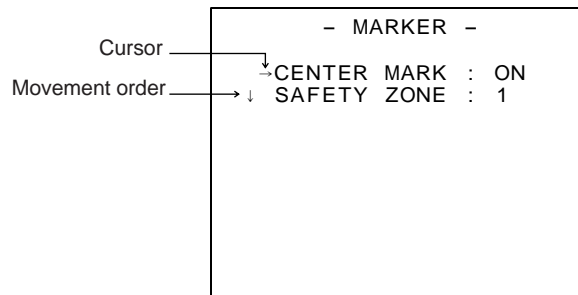

The item can also be selected using the UP and DOWN buttons as follows.

Changing the settings

Press the UP button to increase the setting.

- The setting is incremented by 1 level each time the UP button is pressed.

Press the DOWN button to decrease the setting.

- The setting is decremented by 1 level each time the DOWN button is pressed.

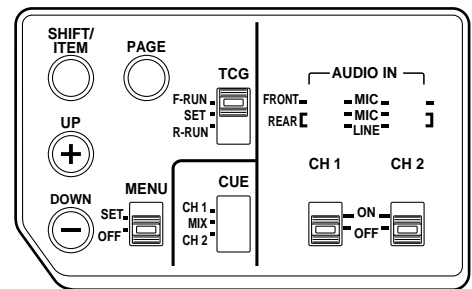

Changing the ON/OFF selection

The setting switches to ON or OFF each time the UP (or DOWN) button is pressed.

Returning to the default settings

The unit can be returned to the default settings (the settings when shipped from the factory) by pressing the UP (or DOWN) button at the DATA RESET page of engineer mode*.

However, care should be taken as the flare and shading adjustment values cannot be returned to the default settings.

Quitting the menu

Set the MENU SET/OFF switch to OFF.

- The setting menu disappears from the viewfinder screen and the displays indicating the unit's current status appear at the top and bottom of the viewfinder screen.

*Engineer mode

The menu for this mode is opened by holding down the SHIFT/ITEM and UP buttons simultaneously and then setting the MENU SET/OFF switch to the "SET" position.

Lamp Displays Inside the Viewfinder

The viewfinder displays are as follows.

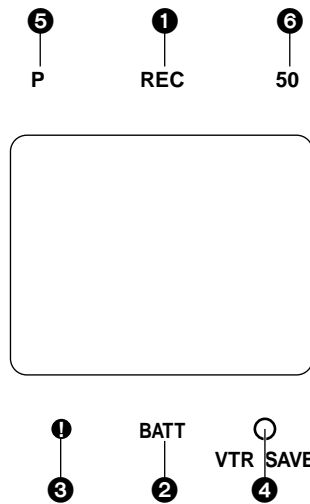

1. REC (recording) lamp

This lamp lights (red) during recording, and flashes when warnings are issued.

•See “Warning System” (page 125) for a detailed description.

2. BATT (battery) lamp

When the battery voltage has dropped, this lamp begins flashing several minutes before the unit can no longer be operated, and lights when the unit can no longer be operated.

To prevent operation from being interrupted, exchange the battery quickly before the battery runs out.

3. ! (irregular operation status warning) lamp

This lamp lights when the unit enters irregular operation status for any of the items set to ON at the ! LED page of the setting menu. Applicable items are as follows.

Setting item	Setting contents
Gain (0 dB)	The gain is set to a value other than 0 dB.
Gain (−3 dB)	The gain is set to a value other than −3 dB.
SHUTTER switch	The switch is set to ON.
WHITE PRESET switch	The switch is set to PRESET.
Lens extender	The lens extender is being used.
Filter control	The control is set to a value other than 1.

•See “Setting the ! Lamp Display” (next page) for selecting ! lamp display items.

4. VTR SAVE (VTR power saving) lamp

This lamp lights when the VTR SAVE/STBY switch is set to SAVE. It is not lighted during recording.

5. P (progressive recording/playback) lamp

This lamp lights when the progressive signal recording mode has been selected and when a tape is played back in the progressive mode.

6. 50 (50 Mbps recording/playback) lamp

This lamp lights when the mode for recording regular interlace signals at 50 Mbps has been selected and when a tape with interlace signals is played back at 50 Mbps.

<Note>

Regardless of the VTR SAVE/STBY switch, the unit automatically enters the SAVE state and the lamp lights either after two minutes when in the stopped state, or after the length of time set for the pause timer (the pause time) when in the paused state.

Lamp Displays Inside the Viewfinder

Setting the ! Lamp Display

Items subject to ! lamp display are selected at the ! LED page of the setting menu. (When shipped from the factory, the unit is set so that the ! LED page is not displayed.) To operate the ! LED page, switch the unit to engineer mode or select the ! LED page at the MENU SELECT page.

• See “Setting Menu Configuration” (page 47) for engineer mode and selection of displayed pages.

- 1** Set the MENU SET/OFF switch to SET.
The setting status displays disappear from the viewfinder screen, and the page on which the previous setting menu operations were completed appears. (When the menu is used for the first time, the first page appears.)
- 2** Press the PAGE button until the ! LED page shown below appears. (This operation can also be performed using the PAGE+UP/DOWN buttons.)

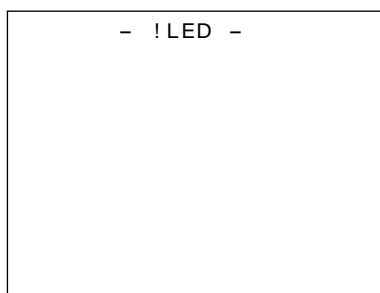

<Note>

*: ON
.: OFF

- | | |
|----------------|---|
| →*GAIN (0 dB): | This selects whether or not the ! lamp lights when the gain is set to any value other than 0 dB. |
| ·GAIN (-3 dB): | This selects whether or not the ! lamp lights when the gain is set to any value other than -3 dB. |
| *SHUTTER: | This selects whether or not the ! lamp lights when the SHUTTER switch is set to ON. |
| ·WHITE PRESET: | This selects whether or not the ! lamp lights when the white balance memory channel is PRST. |
| *EXTENDER: | This selects whether or not the ! lamp lights when the lens is in EXTENDER mode. |
| *FILTER: | This selects whether or not the ! lamp lights when the filter is set to any value other than 3200K. |
- 3** Repeatedly press the SHIFT/ITEM button to move the cursor to the position of the desired item.
 - 4** Press the UP and DOWN buttons to choose ! lamp lighted/not lighted for the selected item.
To select ON: Press the UP button. An asterisk (*) appears to the left of the item name.
To select OFF: Press the DOWN button. A period (·) appears to the left of the item name.
Repeat steps 3 and 4 to continue making ON/OFF settings for other items.
 - 5** When menu operations have been completed, set the MENU SET/OFF switch to OFF.
The setting menu disappears from the viewfinder screen and the displays indicating the unit's current status appear at the top and bottom of the viewfinder screen.

Status Displays Inside the Viewfinder Screen

In addition to images, messages indicating the unit's settings and operating status appear on the viewfinder screen. The center marker and safety zone marker, etc. are also displayed.

When the MENU SET/OFF switch is set to OFF, items set to SET at the VF DISPLAY page of the setting menu and using related switches appear at the top and bottom of the screen.

Messages informing of the setting contents or of the adjustment course or results can also be displayed for approximately 3 seconds when settings are changed, during the course of adjustments, or after adjustments have been completed.

• See "Selecting Display Items" (page 56) for selecting display items, "Display Mode and Setting Change Message" (page 57) for the setting change message, and "Setting the Marker Displays" (page 58) for the marker displays.

The display positions of all items which can be displayed are shown in the figure below.

1. Extender display
2. Shutter speed/mode display
3. Remaining tape length display
4. Remaining battery level display
5. Filter display
6. White balance memory display
7. Gain value display
8. Audio level display
9. Iris value display
10. Warning display
11. Safety zone marker
12. Center marker
13. Super iris ON display
14. TCG (Time Code Generator) display

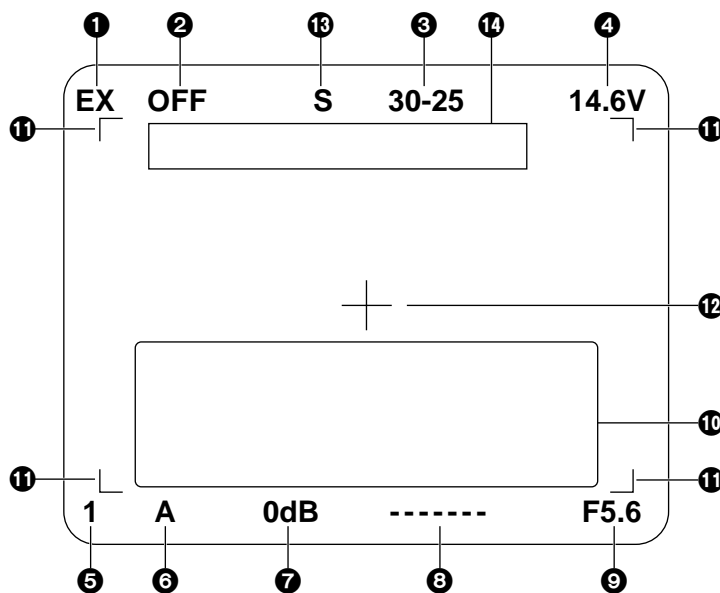

Status Displays Inside the Viewfinder Screen

1 Extender display

This is displayed when the lens extender is being used.

2 Shutter speed/mode display

This displays the shutter speed or shutter mode setting.

OFF (1/60): Fixed at 1/60 (sec.)

1/100, 1/120, 1/250, 1/500, 1/1000:

Shutter speeds (seconds) during standard mode.

1/63.2–1/201.9 (SYNCHRO SCAN):

Synchro scan mode is selected.

3 Remaining tape length display

This indicates the remaining tape length (minutes) for the VTR during recording.

Remaining tape length display

(25 Mbps)

Display	Remaining tape length
F-60	Full to 60 minutes
60-55	60 to 55 minutes
55-50	55 to 50 minutes
50-45	50 to 45 minutes
45-40	45 to 40 minutes
40-35	40 to 35 minutes
35-30	35 to 30 minutes
30-25	30 to 25 minutes
25-20	25 to 20 minutes
20-15	20 to 15 minutes
15-10	15 to 10 minutes
10-5	10 to 5 minutes
5-0	5 to 0 minutes

The "5-0" display flashes when there is less than 3 minutes of tape remaining.

4 Remaining battery level display

When an Anton Bauer Digital Magnum Series battery is used to supply power to the unit, the remaining battery level is displayed numerically (%).

5 Filter display

This displays the type of filter selected.

6 White balance memory display

This displays the selected white balance automatic adjustment memory.

8 Audio level display

This displays the audio CH1 level.

During sine wave input, the audio level display corresponds roughly to the VTR level meter display as follows.



9 Iris value display

This displays the approximate iris setting (F number).

10 Warning display

This displays the black balance, white balance, auto knee function, super iris, super gain and other warning displays.

11 Safety zone marker

This indicates the 80% or 90% (setting when shipped from the factory) range for the viewfinder screen area. The screen area percentage is selected at the MARKER page of the setting menu.

•See "Setting the Marker Displays" (page 58) for a detailed description.

12 Center marker

This indicates the center of the viewfinder screen. This marker is displayed when set to ON at the MARKER page of the setting menu.

13 Super iris ON display

This indicates that the super iris is ON.

14 TCG display

This displays the time code generator value.

1) Iris value display

The iris value is displayed when using a lens with the iris value display function.

Status Displays Inside the Viewfinder Screen

Selecting Display Items

The items to be displayed on the viewfinder screen can be selected by switching the display ON/OFF setting independently for each item at the VF DISPLAY page. The items which can be selected are as follows.

- Display mode (See “Display Mode and Setting Change/Adjustment Course Message”.)
 - Extender display
 - Shutter speed/mode display
 - Remaining tape length display
 - Remaining battery level display
 - Filter display
 - White balance memory display
 - Gain value display
 - Level meter display
 - Iris value/super iris ON status display
 - Camera ID display
- The camera ID is displayed when recording the color bar according to the OUTPUT/AUTO KNEE switch setting. See “Setting the Camera ID” (page 59) for a detailed description.

Select the items to be displayed on the viewfinder screen.

- 1** Set the MENU SET/OFF switch to SET.
The page on which the previous setting menu operations were completed appears on the viewfinder screen. (When the menu is used for the first time, the first page appears.)
- 2** Press the PAGE button until the VF DISPLAY page shown below appears.
(This operation can also be performed using the PAGE+UP/DOWN function.)

Display mode	_____	DISP MODE	: 3
Extender display	_____	EXTENDER	: ON
Shutter speed/mode display	_____	SHUTTER	: ON
Remaining tape length display	_____	TAPE	: ON
Remaining battery level display	_____	BATTERY	: ON
Filter display	_____	FILTER	: ON
White balance memory display	_____	WHITE	: ON
Gain value display	_____	GAIN	: ON
Level meter display	_____	LEVEL METER	: CH1
Iris value/super iris ON status display	_____	IRIS	: S+IRIS
Camera ID display	_____	CAMERA ID	: OFF

- 3** Press the SHIFT/ITEM button to move the cursor to the position of the desired item.
- 4** Press the UP and DOWN buttons to choose whether to display (ON) or not display (OFF) the selected item on the viewfinder screen.
The setting switches to ON or OFF each time the UP (or DOWN) button is pressed.
Repeat steps 3 and 4 when setting display ON/OFF for other items.
- 5** When menu operations have been completed, set the MENU SET/OFF switch to OFF.
The setting menu disappears from the viewfinder screen and the displays indicating the settings of the selected items appear.

Display Mode and Setting Change Message

Messages informing of the contents of changed settings and adjustment results can be limited to part of the displayed items or not displayed for all items.

The conditions under which messages are displayed and the corresponding display modes are shown in the table below.

Setting change/adjustment results messages and display modes

Conditions under which messages are displayed	Message	Display mode setting		
		1	2	3
When the filter selection is changed.	ND: n (n=1, 2, 3, 4)	×	×	○
When the gain setting is changed.	GAIN: n dB (n=-3, 0, 3, 6, 9, 12, 15, 18, 21, 24, 30)	×	×	○
When the WHITE BAL switch setting is changed.	WHITE: n (n=ACH, BCH, PRESET)	×	×	○
When the OUTPUT/AUTO KNEE switch is set to AUTO KNEE or OFF*)	AUTO KNEE: ON (or OFF)	×	○	○
When the shutter speed/ mode setting is changed.	SS: 1/100 (or 1/120, 1/250, 1/500, 1/1000, S. SCAN)	×	○	○
When the white balance is adjusted (AWB)	Ex.) AWB: OK ●See "Adjusting the White Balance" (page 66) for a detailed description.	×	○	○
When the black balance is adjusted (ABB)	Ex.) ABB: OK ●See "Adjusting the Black Balance" (page 69) for a detailed description.	×	○	○

○: Message displayed

×: Message not displayed

*) The message is displayed for approximately 3 seconds immediately after the power for the unit is turned on.

Status Displays Inside the Viewfinder Screen

Changing the Display Mode

The display mode setting appears on the VF DISPLAY page of the setting menu.

- 1** Perform the operations in steps 1 to 3 of “Selecting Display Items” (page 56) to display the VF DISPLAY page of the setting menu on the viewfinder screen and align the cursor with the DISP MODE item.
- 2** Press the UP or DOWN button to select the desired display mode.
- 3** When menu operations have been completed, set the MENU SET/OFF switch to OFF.

Setting the Marker Displays

Display ON/OFF switching for the center and safety zone markers and selection of 80% or 90% of the screen area as the safety marker range are performed at the MARKER page of the setting menu.

- 1** Set the MENU SET/OFF switch to SET.
The page on which the previous setting menu operations were completed appears on the viewfinder screen. (When the menu is used for the first time, the first page appears.)
- 2** Press the PAGE button until the MARKER page shown below appears.
(This operation can also be performed using the PAGE+UP/DOWN function.)

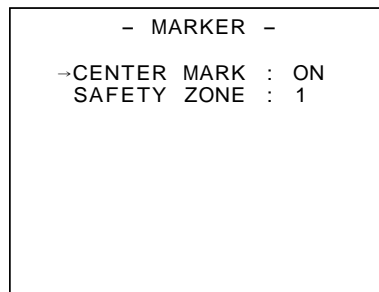

- 3** Press the SHIFT/ITEM button to move the cursor to the position of the desired item.
- 4** The setting switches to ON or OFF each time the UP (or DOWN) button is pressed.
- 5** When menu operations have been completed, set the MENU SET/OFF switch to OFF.
The setting menu disappears from the viewfinder screen and the displays indicating the unit's current status appear at the top and bottom of the viewfinder screen.

Setting the Camera ID

The camera ID can be set at the CAMERA ID page of the setting menu. A camera ID of up to 9 characters including English letters, symbols and spaces can be used. The camera ID is recorded when the OUTPUT/AUTO KNEE switch is set to BARS and the color bar signal is being recorded. It is also displayed on the viewfinder screen.

<Note>

When the setting menu is displayed, the camera ID is not displayed even if the color bar signal is output.

1 Set the MENU SET/OFF switch to SET.
The page on which the previous setting menu operations were completed appears on the viewfinder screen. (When the menu is used for the first time, the first page appears.)

2 Press the PAGE button until the CAMERA ID page shown below appears.
(This operation can also be performed using the PAGE+UP/DOWN function.)

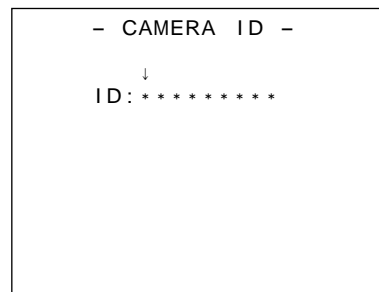

: The cursor is moved to the right (max. 10 spaces) by the SHIFT/ITEM button.

: English letters, symbols and space are switched by the UP and DOWN buttons.

Camera ID

("*" indicates a space. This indication is only used at this menu page.)

3 Press the UP (or DOWN) button until the desired character appears.
Each time the UP button is pressed, the character display changes in the order of English letters (A to Z)→numbers (0 to 9)→symbols [space, >, <,), (, ', ' , ,, --, _ , ~, /, !]. Pressing the DOWN button changes the character display in the reverse order.

4 Press the SHIFT/ITEM button to advance the cursor to the next position and return to step 3 to set the characters.

5 When menu operations have been completed, set the MENU SET/OFF switch to OFF.
The setting menu disappears from the viewfinder screen and the displays indicating the unit's current status appear at the top and bottom of the viewfinder screen.

<Note>

The area under the SMPTE color bars in which the CAMERA ID is mixed automatically changes to gray if CAMERA ID on the VF DISPLAY page is set to ON when SMPTE color bar has been selected for the COLOR BAR selection on FUNCTION page 2 of 5 of the setting menu. Although some minor flickering will occur at the boundary between the SMPTE color bars and the gray, this is not indicative of any trouble.

Displays

Remaining Battery Level and Audio Level Displays

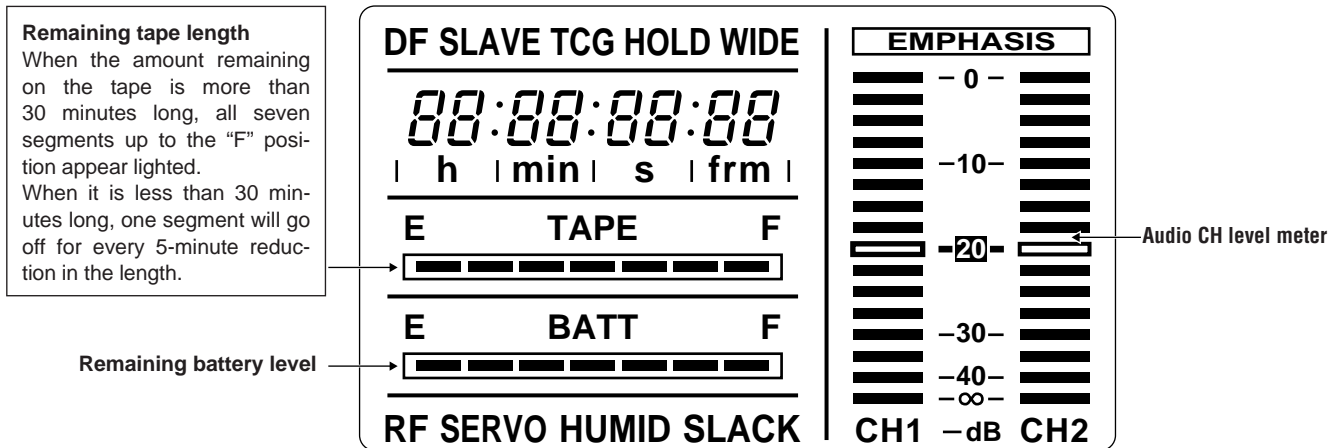

VTR Section Operation/Status-Related Displays

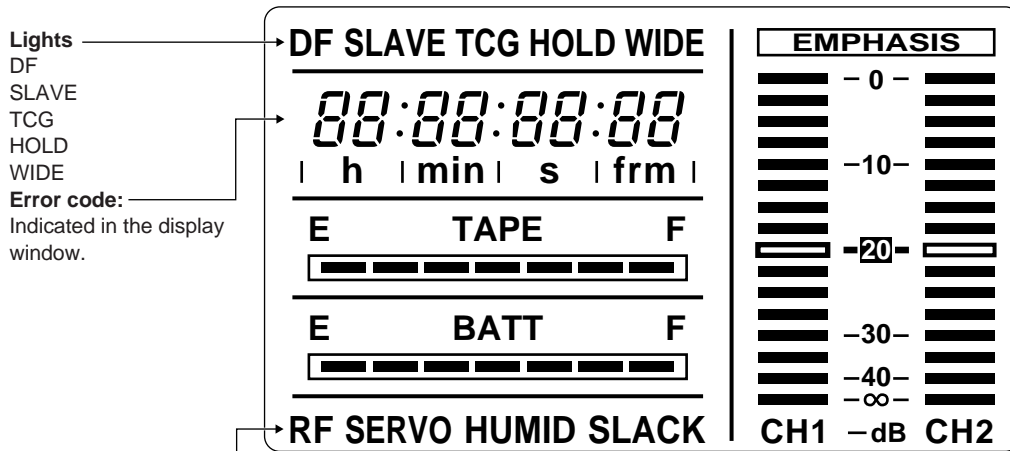

Warning display

- RF:** Lights when video head clogging occurs.
- SERVO:** Lights when the servo is out of order.
- HUMID:** Lights when condensation occurs on the head drum.
- SLACK:** Lights when tape wind-up trouble occurs.

• See "Warning System" (page 125) for a detailed description.

Time Code-Related Displays

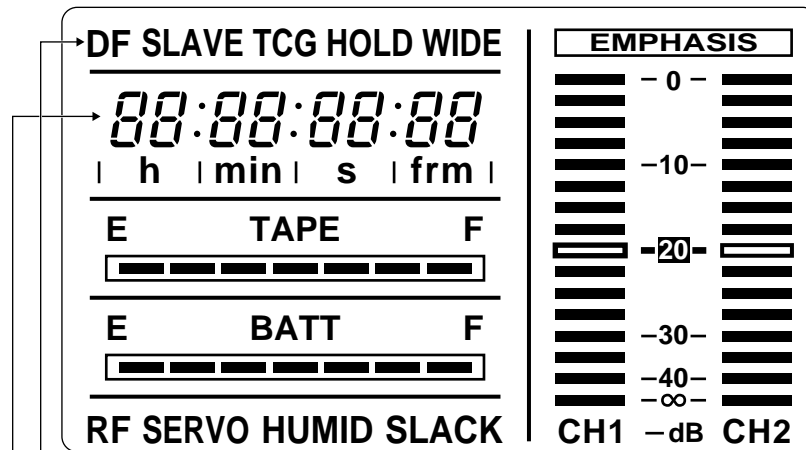

These lamps light to indicate the time code, CTL and real time displays.

DF: This lamp lights during drop frame mode

SLAVE: This lamp lights when the time code is locked to an external source.

HOLD: This lamp lights when the time code generator is held (when the HOLD button is pressed).

WIDE: This lamp lights when a tape is recorded or played back with an aspect ratio of 16:9.

Time counter display: This displays the time code, CTL, user bit and real time.

• See below for the relationship between displayed items and switch settings.

Relationship between the TCG and DISPLAY switch setting positions and the time counter display

The item displayed in the time counter display is determined by the TCG switch and DISPLAY switch settings.

Time code-related switch settings and display items

TCG switch position	DISPLAY switch position	Displayed item
SET	TC or CTL	Time code
	UB	User bit
F-RUN or R-RUN	CTL	CTL
	TC	Time code
	UB	User bit

Adjusting the Time and Date

Adjustment and setup using the setting menu

- 1** Hold down the SHIFT/ITEM and UP buttons and set the MENU SET/OFF switch to SET. The unit switches to ENG mode. The page on which the previous setting menu operations were completed appears on the viewfinder screen.
(When the menu is used for the first time, the first page appears.)
- 2** Press the PAGE button until the TIME/DATE page shown below appears.
(This operation can also be performed using the PAGE+UP/DOWN function.)

```
- TIME / DATE -  
  
->YEAR   : 98  
MONTH   : 01  
DAY     : 01  
HOUR    : 00  
MINUTE  : 00  
  
■ TIME / DATE SET
```

- 3** Press the SHIFT/ITEM button to select the item to be changed.
- 4** Press the UP (or DOWN) button to change the setting value. The number is incremented by +1 each time the UP button is pressed and decremented by -1 each time the DOWN button is pressed.

```
- TIME / DATE -  
  
YEAR    : 98  
MONTH   : 01  
DAY     : 01  
HOUR    : 00  
->MINUTE : 00  
  
■ TIME / DATE SET
```

- 5** When the settings have been completed, press the SHIFT/ITEM button to select TIME/DATE SET and then press the UP (or DOWN) button. The time starts from when the button is pressed.

```
■ T
```

- 6** When menu operations have been completed, set the MENU SET/OFF switch to OFF. The setting menu disappears from the viewfinder screen and the displays indicating the unit's current status appear at the top and bottom of the viewfinder screen.

<Note>

The seconds cannot be set and always start from 0 seconds.

Adjustments and Setup During Recording

Adjustments and Setup Using the Setting Menu

Adjustments and setup operations during recording are performed at the setting menu. Setting menu operations are basically performed according to the procedures described on page 49.

However, these procedures vary slightly according to the item.

Items which can be adjusted or set up at the setting menu are as follows.

Adjustment/setup items at the setting menu

Adjustment/setup item	Page name	Operation reference
Setting the gain selector value	SETTING (LOW/MID/HIGH)	Setting the Gain Selector Value, Setting the DTL and gamma, etc.
Selecting the shutter speed/ mode to be used	SHUTTER SPEED	Setting the Electronic Shutter
Setting the synchro scan mode shutter speed	SYNCHRO SCAN	Setting the Electronic Shutter
Selecting required functions	FUNCTION 1/5 to 5/5	Selecting Functions
Shading adjustment	AUTO SHADING	Shading Adjustment
Setup card data operations	SET UP CARD	Setup Card Operations

Adjustments and Setup During Recording

Setting the Gain Selector Value

When shooting in locations without sufficient brightness, bright images can be obtained by raising the gain. However, care should be taken as raising the gain also increases the noise.

The gain value for the image amplifier is selected by the GAIN switch. The gain values corresponding to the L, M and H positions of the GAIN switch are set at the MASTER GAIN page of the setting menu.

Setting the gain selector value

- 1** Set the MENU SET/OFF switch to SET.
The page on which the previous setting menu operations were completed appears on the viewfinder screen.
(When the menu is used for the first time, the first page appears.)
- 2** Press the PAGE button to display the SETTING (LOW/MID/HIGH) page shown below.
(This operation can also be performed using the PAGE+ UP/DOWN function.)

```
- LOW  SETTING (16*9/P) -  
->MASTER GAIN   : 0dB  
  H.DTL LEVEL   : 12  
  V.DTL LEVEL   : 14  
  DTL CORING    : 02  
  H.DTL FREQ.   : 04  
  V.DTL FREQ.   : P  
  DARK DTL      : 00  
  LEVEL DEPEND  : 01  
  MASTER GAMMA  : 0.45  
  BLACK STRETCH : OFF  
  MATRIX TABLE : A
```

- 3** Press the SHIFT/ITEM button repeatedly to move the cursor to the MASTER GAIN position.
- 4** Press the UP or DOWN button to set the gain value.
The gain value can be set freely regardless of size from among -3, 0, 3, 6, 9, 12, 15, 18, 21, 24 and 30 dB.
When resetting the gain values to the settings when shipped from the factory (LOW=0 dB, MID=9 dB, HIGH=18 dB), select MENU INIT. at the DATA RESET page of the setting menu and press the UP or DOWN button.
- 5** When menu operations have been completed, set the MENU SET/OFF switch to OFF.
The setting menu disappears from the viewfinder screen and the displays indicating the unit's current status appear at the top and bottom of the viewfinder screen.

Selecting Functions

VTR operation functions can be selected at the FUNCTION 3/5 page of the setting menu.

Selecting the required functions

- 1** Set the MENU SET/OFF switch to SET.
The page on which the previous setting menu operations were completed appears on the viewfinder screen.
(When the menu is used for the first time, the first page appears.)
- 2** Press the PAGE button to display the FUNCTION 3/5 page.
(This operation can also be performed using the PAGE+UP/DOWN function.)

- FUNCTION 3 / 5 -	
→HUMID OPE	:OFF
26P CONTROL	:OFF
REC START	:NORMAL
TC MODE	:DF
UB MODE	:USER
PAUSE TIMER	:30
BATTERY SEL	:NiCd-12
TCG VF DISP	:OFF
TCG SET HOLD	:OFF

- 3** Press the SHIFT/ITEM button to move the cursor to the position of the function to be changed.
- 4** Press the UP (or DOWN) button to change the setting of the selected function.
If settings for other functions are also to be changed, return to step 3.
- 5** When menu operations have been completed, set the MENU SET/OFF switch to OFF.
The setting menu disappears from the viewfinder screen and the displays indicating the unit's current status appear at the top and bottom of the viewfinder screen.

Adjusting the White Balance/Black Balance

Adjusting the White Balance

Adjusting the white balance and black balance in the order of AWB (white balance adjustment)→ABB (black balance adjustment)→AWB will provide a better picture.

Normally, the white balance and black balance do not need to be readjusted even if the power is turned off and then on again.

However, the white balance must be readjusted when the lighting conditions change.

If black balance and white balance adjustments are started when the display mode is set to “2” or “3”, messages informing of the adjustment course and results will appear on the viewfinder screen. Set the display mode to “1” to not display these messages.

• See “Display Mode and Setting Change Message” (page 57) for a description of setting the display mode.

<Notes>

- The white balance and black balance cannot be adjusted while the setting menu appears on the viewfinder screen. Therefore, be sure to set the MENU SET/OFF switch to OFF.
- The auto black balance (ABB) must always be re-adjusted when the MASTER GAIN value for the LOW SETTING, MID SETTING or HIGH SETTING on the setting menu has been changed, when the super gain setting has been changed using the SUPER GAIN button, and when the GAMMA setting (ON/OFF) on setting menu FUNCTION 1/5 page has been switched.
- With artificial lights, particularly with fluorescent lights and mercury-arc lamps, the strength of the R, G and B colors changes in synchronization with the power line frequency even if the brightness of these lights appears to be constant. Especially in areas where the power line frequency is 50 Hz, the vertical synchronizing frequency (approx. 60 Hz) of the NTSC and the frequency (50 Hz) of the lighting tend to interact. This gives rise to flicker and to a phenomenon where the hue changes along with the passage of time, and it is impossible to obtain the proper white balance.

These phenomena can be reduced by setting the shutter speed to 1/100. For this reason, wherever the unit is used under fluorescent or mercury-arc lamps and at a frequency of 50 Hz, the shutter speed must be set to 1/100 and the white balance obtained. This shutter speed of 1/100 should also be used during shooting.

- 1 Set the switches as shown in the figure.

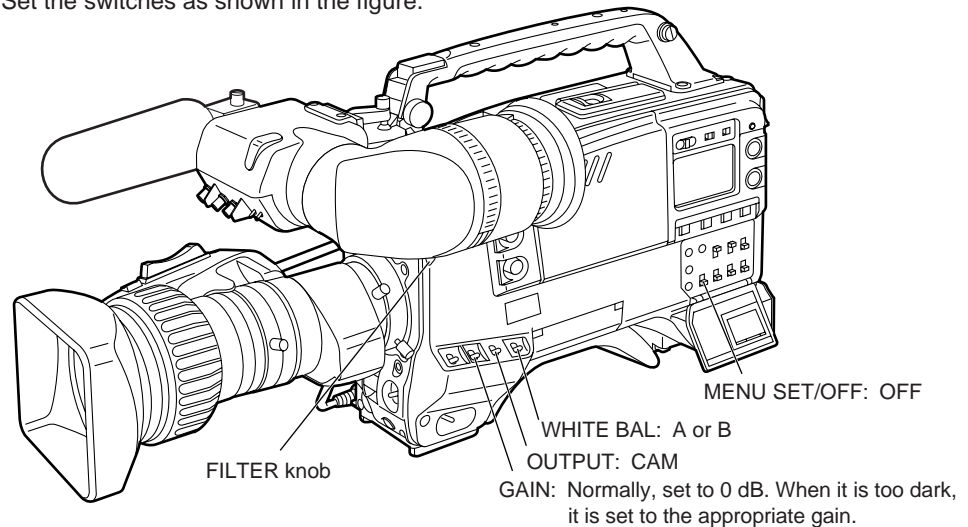

If the settings of the GAIN and WHITE BAL switches are changed, a message informing of the new setting will appear for about 3 seconds at the setting change message display position on the viewfinder screen. (However, the message appears only when the display mode is set to “3”.)

- 2 Select the FILTER knob setting in accordance with the lighting conditions.
 - See FILTER knob (page 15) in the Shooting (Recording)/Playback Function Section for examples of FILTER knob settings. If the setting of the FILTER knob is changed, a message informing of the new setting will appear for about 3 seconds at the setting change message display position on the viewfinder screen. (However, the message appears only when the display mode is set to “3”.)

- 3** Place the white pattern over a location with the same conditions as the light source illuminating the subject and zoom up to project white on the screen. A white object (white cloth, white wall) near the subject can also be used. The white area required is as shown below.

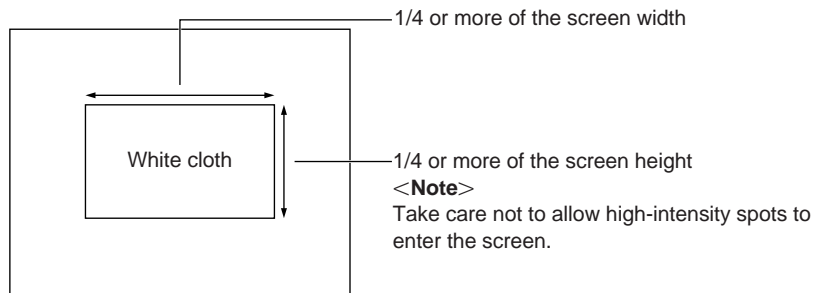

- 4** Adjust the iris of the lens.
- 5** Press the AUTO W/B BAL switch to the WHT side and release the switch. The switch returns to the center and the white balance is automatically adjusted.

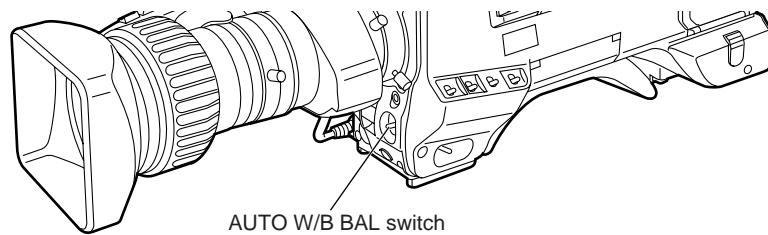

- 6** During the adjustment, the following message appears on the viewfinder screen. (However, the message appears only when the display mode is set to "2" or "3".)



Message during adjustment

- 7** Adjustment is completed after approximately 1 second (the following message appears) and the adjustment value is automatically stored in the memory (A or B) selected in step 1.

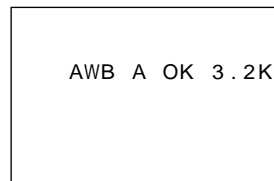

Message after adjustment is completed

<Note>

If a lens equipped with the automatic iris function is used, the iris may experience hunting¹⁾. In these cases, adjust the iris gain knob (the knob marked IG, IS, S, etc.) on the lens.

- See the Handling Instructions for the lens for a detailed description.

1) Hunting: The auto iris responds repeatedly causing the image to become darker and brighter.

Adjusting the White Balance/Black Balance

When the White Balance Cannot be Automatically Adjusted

An error message will appear on the viewfinder screen.

(The message appears when the display mode is set to “2” or “3”.)

The displayed messages are as follows.

Error messages related to white balance adjustment

Error message	Meaning	Treatment
COLOR TEMP. HIGH	The color temperature is too high.	Select an appropriate filter
COLOR TEMP. LOW	The color temperature is too low.	Select an appropriate filter.
LOW LIGHT	There is insufficient illumination.	Increase the illumination or gain.
LEVEL OVER	There is too much illumination.	Decrease the illumination or gain.
UNSTABLE CONDITION	The shooting conditions are unstable (shooting is taking place under fluorescent lighting or the camera is not being held or pointed properly, etc.).	If flickering is a problem, turn the SHUTTER switch to ON and stabilize the shooting conditions.

If the above error messages appear, carry out the respective treatment attempt to adjust the white balance again.

If the error message continues to appear even after repeated attempts, consult your dealer.

<Note>

The white balance cannot be adjusted while the setting menu is displayed on the viewfinder screen. Therefore, be sure to set the MENU SET/OFF switch to OFF.

When there is no Time to Adjust the White Balance

Set the WHITE BAL switch to PRST.

The white balance for the filter is automatically adjusted according to the setting position of the FILTER knob (outside).

White balance memories

The white balance has two memory systems: A and B.

Adjustment values for each filter can automatically be stored in the memory corresponding to the setting (A or B) of the WHITE BAL switch. The unit contains 4 filters, making a total of 8 (4×2) adjustment values which can be stored.

If FILTER INH on the FUNCTION 2/5 page of the setting menu is set to ON, the A and B systems can be limited to one memory each.

In this case, the memory contents are not linked to the filters.

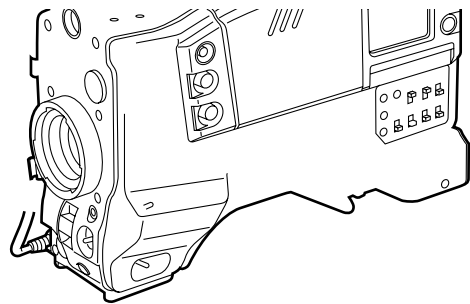

Adjusting the White Balance/Black Balance

- 4** Adjustment is completed after a few seconds (the following message appears) and the adjustment value is automatically stored in the memory.

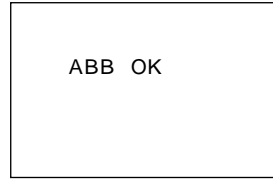

Message after adjustment is completed

<Notes>

- Check that the lens connector is connected and that the iris of the lens is set to CLOSE.
- During black balance adjustment, the iris automatically goes to the shaded status.
- During black balance adjustment, the gain selector circuit switches automatically.
In addition, flicker and noise may appear on the viewfinder screen, but this does not indicate a malfunction.
- The black balance cannot be adjusted while the setting menu is displayed on the viewfinder screen. Therefore, be sure to set the MENU SET/OFF switch to OFF.
- If black shading is not satisfactory even when ABB is OK, open the AUTO SHADING page of the setting menu and execute black shading adjustment. (See page 124.)

Setting the Electronic Shutter

Shutter Modes

The shutter modes which can be used with the unit's electronic shutter and the shutter speeds which can be selected are as follows.

Shutter modes and shutter speeds which can be selected

Mode	Shutter speed	Application
Standard	1/100, 1/120, 1/250, 1/500 and 1/1000 (seconds)	This mode is used to shoot clear images of quickly moving subjects.
SYNCHRO SCAN	248 steps in the range from 63.2 Hz to 201.9 Hz	This mode is used to reduce horizontal stripe patterns for monitor screens with a vertical scanning frequency of 60 Hz or more.

<Notes>

- Increasing the shutter speed lowers the camera sensitivity regardless of electronic shutter mode.
- If the iris is set to AUTO, the iris opens and the depth of the focuses decreases as the shutter speed rises.

Setting the Electronic Shutter

Setting the Shutter Mode/Speed

- The shutter speed during shutter mode and standard mode is set by the SHUTTER switch.
- During SYNCHRO SCAN mode, the shutter speed can be set beforehand at the SYNCHRO SCAN page of the setting menu. In the SYNCHRO SCAN mode, the shutter speed can easily be changed using the SYNCHRO (“+” and “-”) buttons. (It can also be set using the UP or DOWN button.)
- The shutter speed selection range can be limited to the required range and whether to use SYNCHRO SCAN mode can be selected at the SHUTTER SPEED page of the setting menu.

1 Perform the operations outlined in “Changing the Display Mode” (page 58) and set the display mode to “2” or “3” at the VF DISPLAY page of the setting menu.

2 Press the SHUTTER switch from the ON position to the SEL side. The current shutter setting appears in the setting change message display position on the viewfinder screen.

Ex.: 1/120, 1/63.2, etc.

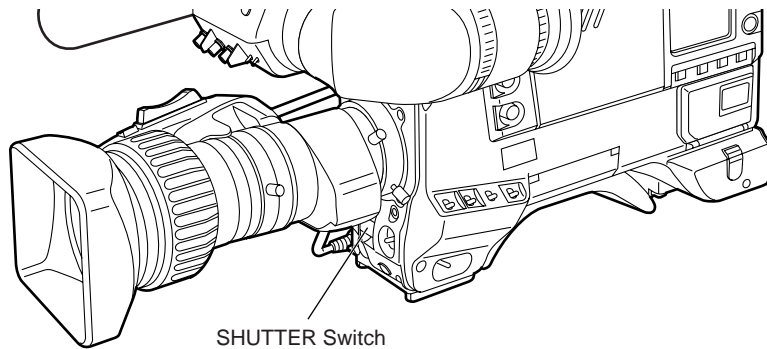

3 Press the SHUTTER switch to the SEL side repeatedly until the desired mode or speed appears. When all modes and speeds can be displayed, the display changes in the order shown below. If the required shutter speeds and modes have been designated beforehand, only the designated speeds or modes appear.

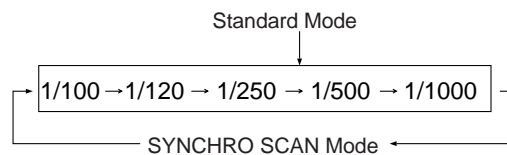

Setting the Synchro Scan Mode

- 1** Set the MENU SET/OFF switch to SET.
The page on which the previous setting menu operations were completed appears on the viewfinder screen. (When the menu is used for the first time, the first page appears.)
- 2** Press the PAGE button repeatedly until the SYNCHRO SCAN page shown below appears. (This operation can also be performed using the PAGE+UP/DOWN function.)

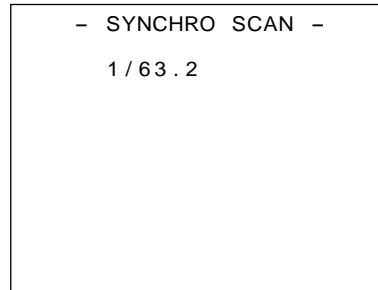

- 3** Press the UP (the value increases) or DOWN (the value decreases) button repeatedly to display the desired frequency. The frequency can be switched continuously within the range of 63.2 Hz to 201.9 Hz.
- 4** When menu operations have been completed, set the MENU SET/OFF switch to OFF. The setting menu disappears from the viewfinder screen and the displays indicating the unit's current status appear at the top and bottom of the viewfinder screen. Pressing the SYNCHRO ("+" and "-") buttons in the SYNCHRO SCAN mode results in the same operation which is performed when the UP and DOWN buttons mentioned above are pressed.

<Note>

The picture may be subject to changes (flickering) for a moment when the frequency is switched in the synchro scan mode. This is normal and not an indication of trouble.

Setting the Electronic Shutter

Changing the Shutter Speed/Mode Selection Range

The shutter speed selection range can be limited to the required range and whether to use a SYNCHRO SCAN mode can be selected at the SHUTTER SPEED page of the setting menu. The unit is set so that the SHUTTER SPEED page is not displayed when shipped from the factory. To operate the SHUTTER SPEED page, switch the unit to engineer mode or select the SHUTTER SPEED page at the MENU SELECT page beforehand.

- 1** Set the MENU SET/OFF switch to SET.
The page on which the previous setting menu operations were completed appears on the viewfinder screen. (When the menu is used for the first time, the first page appears.)
- 2** Press the PAGE button repeatedly until the SHUTTER SPEED page shown below appears. (This operation can also be performed using the PAGE+UP/DOWN function.)

```
- SHUTTER SPEED -  
→ * SYNCHRO SCAN  
  * 1 / 100  
  * 1 / 120  
  * 1 / 250  
  * 1 / 500  
  * 1 / 1000
```

<Note>

The ON/OFF status for each item is indicated by displaying an asterisk (*) or period (·) in front of the item on the screen.

- 3** Press the SHIFT/ITEM button repeatedly to move the cursor to the position of the mode or shutter speed to be set.
- 4** The selected mode or speed changes from used (ON) to not used (OFF) and vice versa each time the UP (or DOWN) button is pressed.
- 5** When menu operations have been completed, set the MENU SET/OFF switch to OFF. The setting menu disappears from the viewfinder screen and the displays indicating the unit's current status appear at the top and bottom of the viewfinder screen.

<Note>

When operating the unit from the AQ-EC1 extension control unit (option), even if the SHUTTER SPEED page is operated from the unit, the switches of the AQ-EC1 have priority regarding the actual shutter speed.

- See "Setting Menu Configuration" (page 47) for a description of engineering mode and selecting display pages.

Changing the Iris Automatic Adjustment Reference Value

To change the reference value, change the A. IRIS LEVEL, A. IRIS PEAK/AVE, A. IRIS MODE value on the LEVEL 6/6 page of the setting menu using the UP or DOWN button.

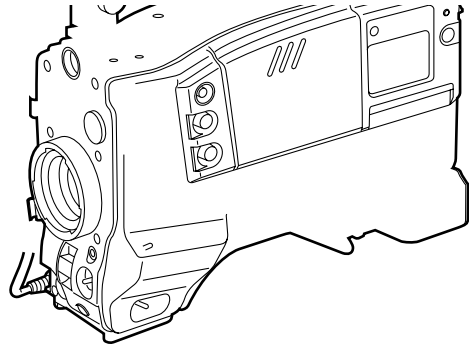

Adjusting the Audio Level

- 4** Turn the AUDIO LEVEL CH1 control at the bottom of the front panel to adjust the input volume so that the audio level display appears as shown below.
- When the input volume is normal, the audio level display turns ON up to the seventh of the eight level display bars from the left.
 - When the rightmost (0 dB) turns asterisk (*) mark, the input volume is excessive. Adjust the level so that the display bar does not turn * mark.



When the optimal level cannot be set

The maximum attenuation of the AUDIO LEVEL CH1 control at the bottom of the front panel is about 20 dB. When the optimal level cannot be set within this range, adjust the level using the AUDIO LEVEL CH1 control on the side panel.

Using the AUDIO LEVEL CH1 controls at the bottom of the front panel and on the side panel

Normally, the control at the bottom of the front panel is turned completely to the right and the recording level is adjusted using the control on the side panel.

The control at the bottom of the front panel is used to throttle the level when the input level increases suddenly during recording.

Setting the Time Data

Setting the Time Code

When using both the user bit and the time code, set the user bit first. If the time code is set first, the time code generator will stop while the user bit is being set, causing the set time code to become inaccurate. The time code can be set within the range of 00:00:00:00 to 23:59:59:29.

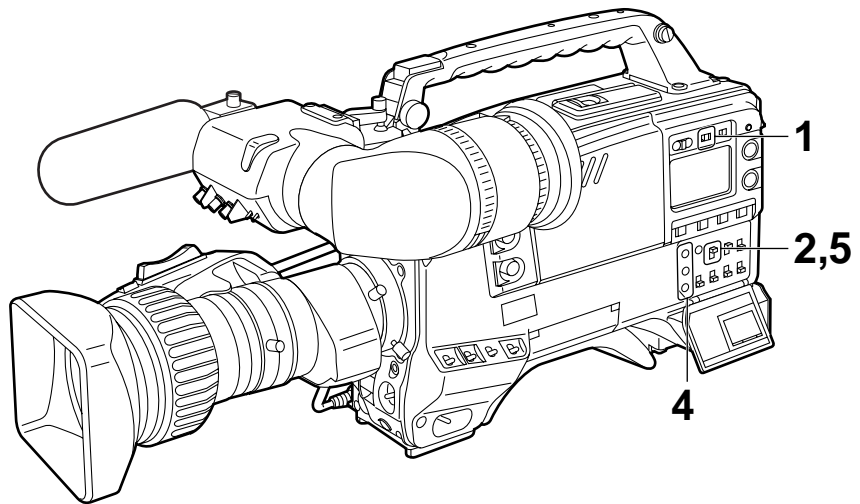

- 1** Set the DISPLAY switch to TC.
- 2** Set the TCG switch to SET.
- 3** Set TC MODE on the FUNCTION 3/5 page of the setting menu to DF or NDF. Select DF when the time code is to be advanced during drop frame mode, and NDF when the time code is to be advanced during non-drop frame mode.
- 4** Set the time code using the SHIFT/ITEM, UP and DOWN buttons.
SHIFT/ITEM button: This is used to cause the digit which is to be set to flash. Each time it is pressed, the flashing digit moves to the right.
UP button: This increments by 1 the figure of the flashing digit.
DOWN button: This decrements by 1 the figure of the flashing digit.
- 5** Set the TCG switch.
Set the switch to F-RUN when the time code is to be advanced regardless of the VTR's operation.
Set the switch to R-RUN when the time code is to be advanced only while recording is in progress.

Time code status during battery replacement

The back-up mechanism functions even while replacing the battery to allow the time code generator to continue operating for extended periods of time (approx. 1 year).

Setting the Time Data

Setting the User Bit

Setting the user bit allows up to 8 digits of hexadecimal data such as memos (date, time), etc. to be recorded in the sub code track.

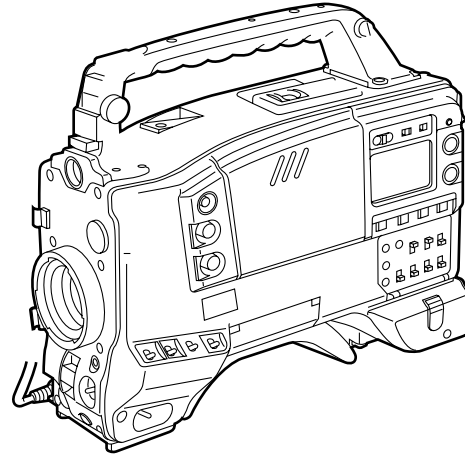

- 1 Set the DISPLAY switch to UB.
- 2 Set the TCG switch to SET.
- 3 Select the UB MODE on the FUNCTION 3/5 page of the setting menu.
- 4 Set the user bit using the SHIFT/ITEM, UP and DOWN buttons.
SHIFT/ITEM button: This is used to cause the digit which is to be set to flash. Each time it is pressed, the flashing digit moves to the right.
UP/DOWN buttons: These increment/decrement by 1 the figure of the flashing digit.

The hexadecimal characters A to F appear as follows.

Hexadecimal	A	B	C	D	E	F
Display						

- 5 Set the F-RUN/R-RUN switch to F-RUN or R-RUN.

User bit memory function

The user bit setting (except for the real time) is automatically stored in the memory and held even after the power is turned off. However, care should be taken as the settings are not stored in the memory if the time from when the power was turned on until the setting operations are completed and the power is turned off is less than 20 seconds.

<Notes>

- When REAL has been selected for UB MODE, the values set for HOUR and MINUTE on the TIME/DATE page apply.
- If REAL has been selected for UB MODE and the DISPLAY switch is set to UB, the LCD display is held when the menu switch is set to SET.

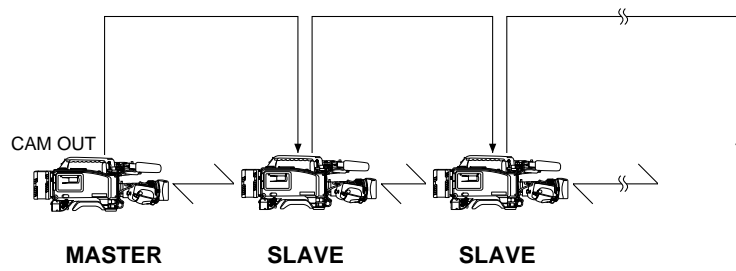

Setting the Time Data

External Lock Operation Procedure

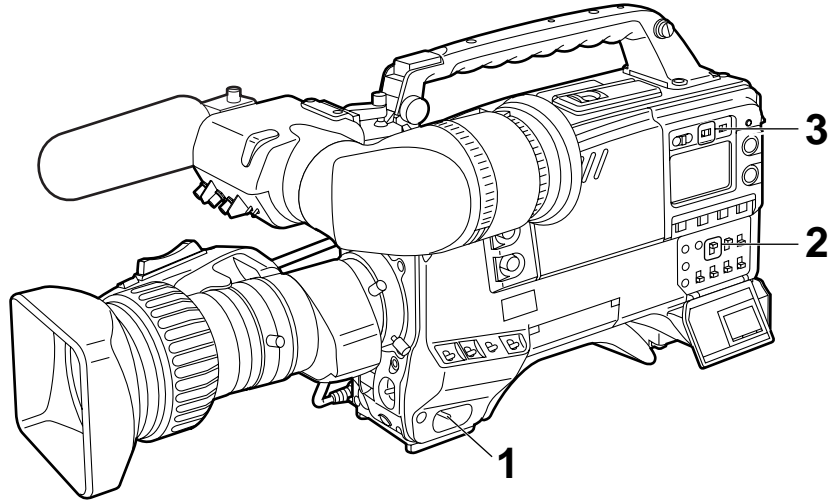

- 1** Set the POWER switch to ON.
- 2** Set the F-RUN/R-RUN switch to F-RUN.
- 3** Set the DISPLAY switch to TC.
- 4** Supply reference time code and reference video signals with a phase relationship which meets the time code standards to the TC IN and GENLOCK IN connectors, respectively.

This locks the built-in time code generator to the reference time code. After about 10 seconds have passed since the time code generator was locked, the external lock status is maintained even if the external reference time code is disconnected. However, if the reference time code is disconnected during recording (REC), the servo lock will be thrown out of order.

<Note>

When the external locking operation is performed, the time code is locked instantly to the external time code and the same value as the external code value appears in the counter display position. Do not set the VTR to recording mode for several seconds until the sync generator has stabilized.

Setting Time Data

User bit setting during external locking

When the time code is locked to an external source, only the time data is locked to the time data of the time code from the external source. Accordingly, the user bit can be set independently for each unit. The user bit can also be locked to the user bit of the time code from the external source.

- Consult your dealer for a detailed explanation.

Releasing the external lock

Stop supplying the external time code and then set the F-RUN/R-RUN switch to R-RUN.

Switching the power supply from the battery to an external power supply during external locking

In order to maintain power supply continuity for the time code generator, connect the external power supply to the DC IN connector before unplugging the battery pack. If the battery pack is unplugged first, the external locking continuity of the time code cannot be assured.

Synchronizing the camera section to an outside source during external locking

While the time code is locked to an external source, the camera section is genlocked by the reference video signal input to the GENLOCK IN connector.

Setup Card Operations

Setting menu contents can be stored using setup memory cards (SHL-064HSRVS, option). This data can then be used to quickly recreate the appropriate setup conditions. Subject data, etc. can also be stored on setup cards. See the Setup Card Application Instructions for a detailed description.

- Optional cards include the general purpose memory card (SRAM 64 KB or more) which is used as the setup card.

Setup Card Handling

Setup cards can be inserted and ejected regardless of whether the power is on or off. However, setup cards should not be inserted or ejected during recording as this may result in misoperation.

Ejecting setup cards

Lift up on the lower edge of the cover to open the cover and remove the setup card.

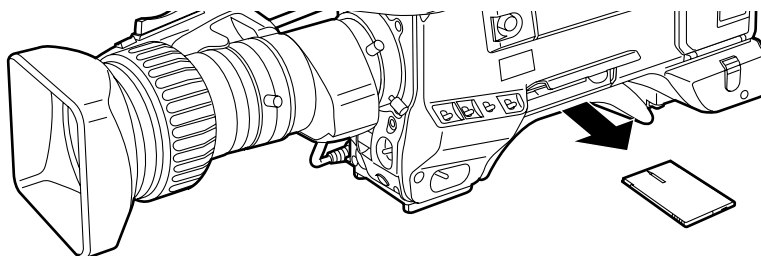

<Note>

Take care not to touch the connectors at the front of the setup card.

Inserting setup cards

Position the unit so that the panel with the logo faces you, insert the setup card into the setup card insertion slot and then close the cover.

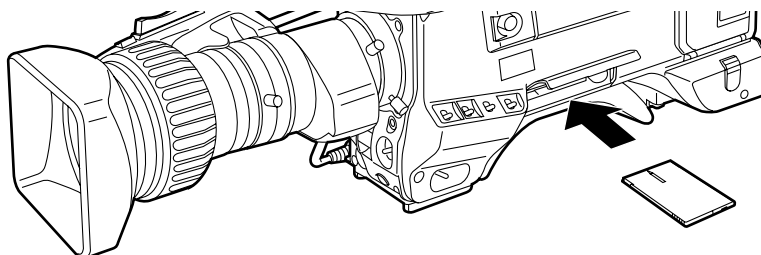

<Note>

Check that the unit is positioned with the logo facing you and that the characters are facing the correct direction, and then insert the card. Be sure to insert the card in the correct direction. If the card is difficult to insert, the card may be backwards or upside-down. In these cases, do not attempt to force in the card, but check whether the card is backwards or upside-down and then reinsert the card.

Usage and storage precautions

The following points should be observed when using and storing setup cards.

- Avoid high temperatures and humidity.
- Do not expose setup cards to water.
- Avoid electrostatic charges.

Store setup cards inserted in the unit with the cover closed.

Setup Card Operations

Setup Card Data Operations

Operations to store setting data on setup cards and read out stored data are performed at the SET UP CARD page of the setting menu.

<Note>

When operating the unit with a remote controller, the SET UP CARD page cannot be operated from the unit.

Formatting setup cards

- 1** Set the MENU SET/OFF switch to SET. The page on which the previous setting menu operations were completed appears on the viewfinder screen. (When the menu is used for the first time, the first page appears.)
- 2** Press the MENU switch repeatedly until the SET UP CARD page shown below appears. (This operation can also be performed using the PAGE+ UP/DOWN function.)

When data is not written

If the following error messages appear when the UP button is pressed in step 5, the data is not written.

Data format error messages

Error message	Condition	Countermeasure
WRITE PROTECT	The write protect switch on the side of the card is set to ON.	Set the write protect switch on the side of the card to OFF.
NO CARD	A setup card is not inserted.	Insert a card.
ERROR	The disk cannot be formatted.	The card may be defective. Replace the card.

Setup Card Operations

Writing set data to cards

- 1 Set the MENU SET/OFF switch to SET. The page on which the previous setting menu operations were completed appears on the viewfinder screen. (When the menu is used for the first time, the first page appears.)
- 2 Press the MENU switch repeatedly until the SET UP CARD page shown below appears. (This operation can also be performed using the PAGE+UP/DOWN function.)

```
- SET UP CARD -  
-READ (-CAM)  
WRITE (-CARD)  
CARD CONFIG.  
ID READ/WRITE :OFF  
FUNCTION1~2R/W:ON  
L/M/H SET R/W :ON  
LEVEL 1~6 R/W :ON
```

- 3 Press the SHIFT/ITEM button repeatedly to move the cursor to the WRITE (→CARD) position.
- 4 A menu shown below appears when the UP (or DOWN) button is pressed.

```
- SET UP CARD -  
READ (-CAM)  
-WRITE (-CARD)  
CARD CONFIG.  
ID READ/WRITE :OFF  
FUNCTION1~2R/W:ON  
L/M/H SET R/W :ON  
LEVEL 1~6 R/W :ON  
  
WRITE?(Y:UP.N:DOWN)
```

- 5 Press the UP button to write data on the set up card. When writing is complete, the message shown below appears.

```
- SET UP CARD -  
READ (-CAM)  
-WRITE (-CARD)  
CARD CONFIG.  
ID READ/WRITE :OFF  
FUNCTION1~2R/W:ON  
L/M/H SET R/W :ON  
LEVEL 1~6 R/W :ON  
  
WRITE OK
```

- 6 When menu operations have been completed, return the MENU SET/OFF switch to OFF. The setting menu disappears from the viewfinder screen and the displays indicating the unit's current status appear at the top and bottom of the viewfinder screen.

Protecting stored data

If the setup card's WRITE PROTECT switch is set to ON, data is not rewritten even if the UP button is pressed in step 5.

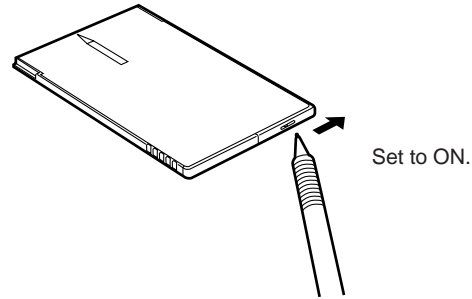

When data is not written

If the following error messages appear when the UP button is pressed in step 5, the data is not written.

Data writing error messages

Error message	Condition	Countermeasure
NO CONFIG	The setup card is not formatted.	Format the card.
NO CARD	A setup card is not inserted.	Insert a card.
WRITE PROTECT	The write protect switch on the side of the card is set to ON.	Set the write protect switch on the side of the card to OFF.
ERROR	Data cannot be written on the card.	The card may be defective. Replace the card.

Setup Card Operations

Reading out data stored on cards

- 1 Set the MENU SET/OFF switch to SET. The page on which the previous setting menu operations were completed appears on the viewfinder screen. (When the menu is used for the first time, the first page appears.)
- 2 Press the PAGE switch repeatedly until the SET UP CARD page appears. (This operation can also be performed using the PAGE+UP/DOWN function.)
- 3 Press the SHIFT/ITEM button to move the cursor to the READ (→CAM) position.
- 4 A menu shown below appears when the UP (or DOWN) button is pressed.

```

- SET UP CARD -

-READ (→CAM)
WRITE (→CARD)
CARD CONFIG.
ID READ/WRITE :OFF
FUNCTION1~2R/W:ON
L/M/H SET R/W :ON
LEVEL 1~6 R/W :ON

READ? (Y:UP .N:DOWN)
```

- 5 Press the UP button to read data from the set up card. When readout is complete, the message shown below appears.

```

- SET UP CARD -

-READ (→CAM)
WRITE (→CARD)
CARD CONFIG.
ID READ/WRITE :OFF
FUNCTION1~2R/W:ON
L/M/H SET R/W :ON
LEVEL 1~6 R/W :ON

READ OK
```

- 6 When menu operations have been completed, set the MENU SET/OFF switch to OFF. The setting menu disappears from the viewfinder screen and the displays indicating the unit's current status based on the data read out from the setup card appear at the top and bottom of the viewfinder screen.

When data is not read out

If the following error messages appear when the UP button is pressed in step 5, the data is not read out.

Data readout error messages

Error message	Condition	Countermeasure
NO CONFIG	The setup card is not formatted.	Format the card.
NO CARD	A setup card is not inserted.	Insert a card.
ERROR	Data cannot be read out.	Data written by devices other than this unit cannot be read out.

Cassettes

- See “Cassettes” (page 135) for a description of cassettes which can be used with the unit.

Inserting and Ejecting Cassettes

Inserting cassettes

- 1 Check that there are no cables, etc. around the cassette holder and the top panel and then set the POWER switch to ON.

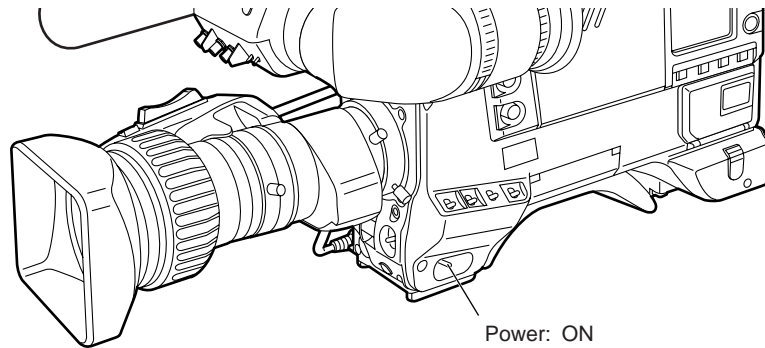

If condensation has occurred inside the unit, the HUMID display lights. In these cases, wait until the display goes off before proceeding to step 2.

- 2 Press the EJECT button. The cassette holder opens.

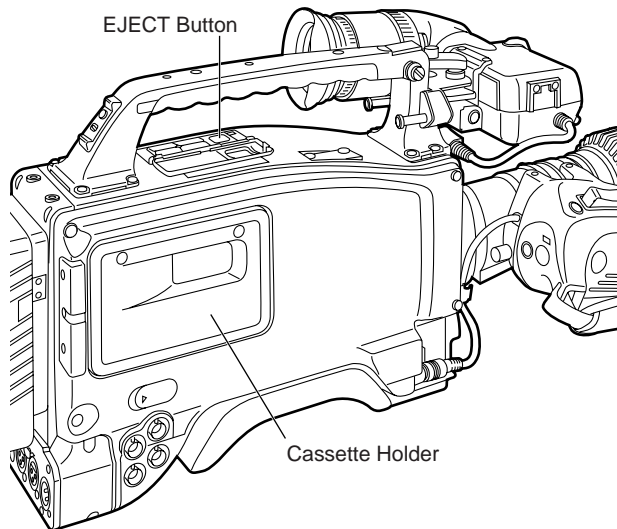

- 3 Check that there is no slack in the tape, insert the cassette, and then firmly close the cassette holder.

Checking that there is no slack in the tape

Press the reel in with your finger and turn it lightly in the direction of the arrow. If the reel does not turn, there is no slack in the tape.

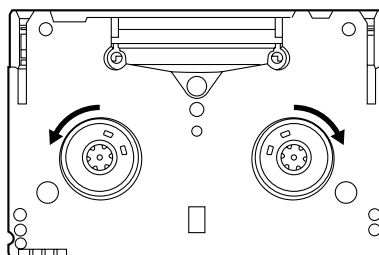

Cassettes

Ejecting cassettes

With the power turned on, press the EJECT button to open the cassette holder and eject the cassette. If a cassette is not to be inserted immediately after ejecting the cassette, close the cassette holder.

Ejecting cassettes when the battery has run out

Set the POWER switch to OFF to turn off the power, then turn on the power again and immediately hold down the EJECT button. If there is still power remaining in the battery, the cassette will be ejected. However, this operation should not be repeated.

Preventing Accidental Erasure

Set the tab on the cassette to the SAVE side to prevent the recorded contents of tapes from being accidentally erased.

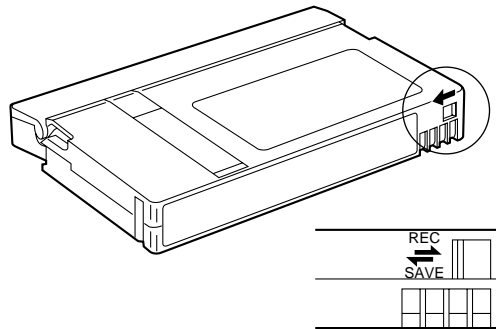

Basic Procedures

This section describes the basic operating procedures for shooting and recording. When starting to shoot actual images, inspect the unit beforehand to check that all systems are functioning normally.

- See the “Inspections Before Shooting” (page 129) for a description of inspection procedures.

Procedures from power supply preparations to inserting a cassette

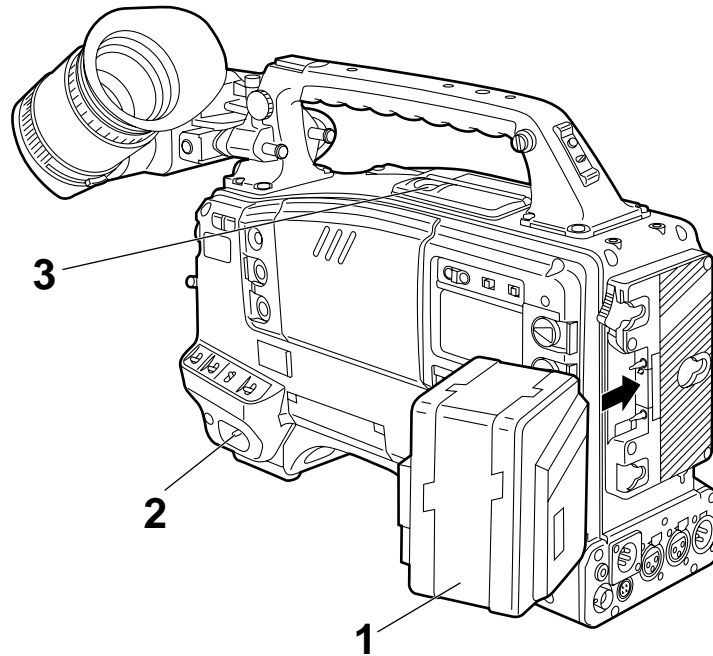

- 1** Insert a charged battery pack.
- 2** Set the POWER switch to ON and check that the HUMID display does not appear and that five or more bars of the remaining battery level display are lighted.
 - If the HUMID display appears, wait until the display goes off.
 - If five or more bars of the remaining battery level display are not lighted, replace the battery pack with a sufficiently charged battery pack.
- 3** Check that there are no cables, etc. around the cassette holder and top panel and then press the EJECT button to open the cassette holder.
- 4** Check the following items, and then insert a cassette and close the cassette holder.
 - The cassette is not set to write protect status.
 - There is no slack in the tape.



Shooting images

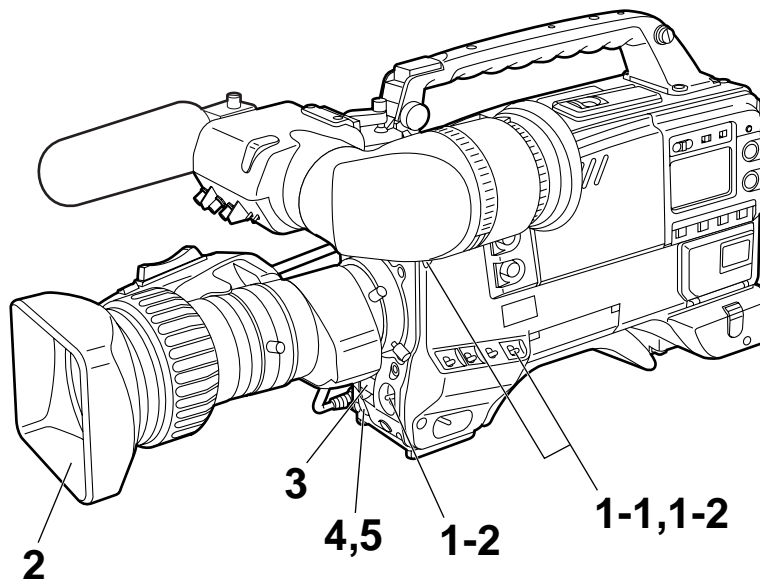

1-1 Select the filter in accordance with the lighting conditions, and when the white balance has already been stored in the memory, set the WHITE BAL switch to “A” or “B”.

When the white balance and black balance have not been stored in the memory and there is no time to adjust the white balance:

Set the WHITE BAL switch to PRST and set the FILTER knob to “1”: this will achieve a 3200 K white balance. (If the knob is set to any other position, a 5600 K white balance is achieved.)

1-2 To adjust the white balance on site, select the filter which corresponds with the lighting conditions, set the WHITE BAL switch to “A” or “B”, and adjust the white balance by following the steps below.

- (1) Press the AUTO W/B BAL switch to the AWB side to adjust the white balance.
- (2) Press the AUTO W/B BAL switch to the ABB side to adjust the black balance.
- (3) Press the AUTO W/B BAL switch to the AWB side to adjust the white balance.

For details on how to adjust the white balance, read through the section entitled “Adjusting the white balance/black balance” (page 66).

2 Aim the camera at the subject and adjust the focus and zoom.

3 When using the electronic shutter, set the shutter speed and operation mode.
• See “Setting the Electronic Shutter” (page 71) for a detailed description.

4 Press the VTR START button of the unit or the VTR button of the lens to start recording. The REC lamp inside the viewfinder lights during recording.

5 Press the VTR START button again to stop recording. The REC lamp inside the viewfinder goes off.

Tape operation buttons

The tape operation buttons (EJECT, REW, FF, PLAY, STOP) do not function during recording.

Recording

Successive Shooting

Successive shooting with an accuracy of within 0–+1 frame can be performed simply by pressing the VTR START button of the unit or the VTR button of the lens while recording is paused.

While recording is paused

The unit automatically searches for the successive shooting point. However, the time until recording starts differs according to the setting of the VTR SAVE/STBY switch.

- If the VTR SAVE/STBY switch is set to SAVE, recording starts about 2 seconds after the VTR START button is pressed.
- If the VTR SAVE/STBY switch is set to STBY, recording starts immediately after the VTR START button is pressed.

Successive shooting when the power is turned off while recording is paused

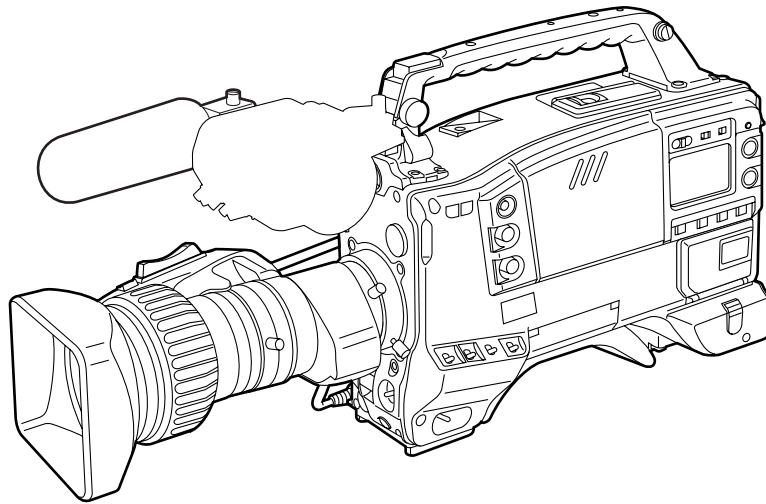

- 1** Turn the power back on.
- 2** Press the VTR START button of the unit or the VTR button of the lens to start recording.

Successive Shooting in Other Cases

If successive shooting is to be performed after the tape has been run, the cassette has been ejected, or when using a tape which has only been recorded part-way, follow the procedures outlined below.

Performing successive shooting after the tape has been run, the cassette has been ejected, or when using a tape which has only been recorded part-way

- 1** Press the PLAY button while watching the viewfinder screen and play back the tape.
- 2** At the place where continuity between frames is to be provided, press the PLAY (or STOP) button again to stop the tape.
- 3** Press the RET button on the lens. Preparations for frame-to-frame continuity are made about two seconds later.
- 4** Press the VTR START button of the unit or the VTR button of the lens to start recording.

Playback—Checking Recorded Contents

Pressing the PLAY button allows black-and-white playback images to be viewed on the viewfinder. Playback images can also be viewed in two other ways.

- **Rec review:** When the RET switch has been set to REC CHECK by MAIN FUNCTION on the setting menu, it is possible to view the last 2 seconds of the recording in the form of black-and-white images in the viewfinder.

- **Color playback:** Connecting a color monitor to the unit's VIDEO OUT connector allows color playback images to be viewed on the monitor.

The playback signal is output to the viewfinder even during rewind (REW) and fast forward (FF). Audio output selection and volume adjustment for the playback signal are performed by the MONITOR switches and knobs on page 13.

Rec Review

If recording is paused and the RET button on the lens is pressed, the tape is automatically re-wound and the playback images for the last two seconds appear on the viewfinder. This allows the recording status to be checked.

After playback, the unit returns to the recording start standby status. Holding down the RET button rewinds and plays back up to 10 seconds of the tape.

<Note>

The rec review function cannot be used unless recording has been performed for more than 1 second.

Color Playback

Connecting a color monitor to the VIDEO OUT connector of the unit allows color playback images to be viewed on the monitor.

Connection With an External VTR

The unit is equipped with an interface which enables recording to be performed by an external VTR.

- Mounting the AJ-YA900P 26-pin/12-pin output adaptor (option) and connecting the 26-pin cable (option) to the unit allows recording to be performed by the VTR section (internal VTR) of the unit and an external VTR. The component video signal is output from the 26-pin interface.

Precautions When Connecting an External VTR

- Set 26P CONTROL on the FUNCTION 3/5 page of the setting menu to BOTH or ON. (The setting is OFF when shipped from the factory.)
- Set SW201 on the CAM ENC board to ON. (Before the unit was shipped from the factory, this switch was set to OFF.)

Power supply

Power is not supplied or received between the unit and the external VTR, so special power supplies should be provided for each unit. The BATT lamp and remaining battery level display function inside the viewfinder indicate the power supply status only for the internal VTR. The power supply status for the external VTR should be checked at the external VTR.

TALLY lamp and REC lamp operation

The unit's TALLY lamp and the REC lamp inside the viewfinder indicate the REC status of the unit when 26P CONTROL is set to BOTH. When 26P CONTROL is set to ON, these lamps indicate the REC status of the external VTR.

Warning tone

External VTR-related warning tones are not output from the unit's speaker or PHONES jack.

Note on connecting cables

The signals may not be connected properly with some cables.

The signal assignments for the 26-pin/12-pin output adaptor AJ-YA900P (optional) are shown in the following table. Use this table as a reference for connection with an external VTR.

Pin No.	Signal	Pin No.	Signal
1	Composite video signal	8	P _B GND
2	Composite video GND	9	CAM MIC (H)
3	Y GND	10	CAM MIC (C)
4	Y signal	11	CAM MIC (GND)
5	P _R signal	12	VTR START/STOP
6	P _R GND	15	REC TALLY
7	P _B signal	B	GND

Recording Simultaneously with the Internal VTR and an External VTR

Connections

Mount the AJ-YA900P 26-pin/12-pin output adaptor (option) to the unit, connect the external VTR with the 26-pin cable, and set the audio input level selector switch of the external VTR to “-60 dB”.

SW201 on the CAM ENC Printed Circuit Board of the unit must be set to ON side.

(See page 98.) Audio input level selector switch: -60 dB

Portable VTR
(Set the audio input level selector switch to -60 dB.)

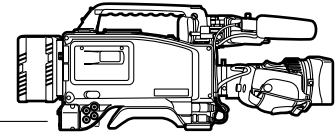

To the 26-pin connector of the AJ-YA900P
(See page 98 for mounting the 26-pin/12-pin output adaptor)

Checking the Function Settings

Check that the settings of the functions which control the 26-pin interface are set to BOTH or ON at the FUNCTION 3/5 page of the setting menu. See “Selecting Functions” for a description of the various function settings.

Starting Recording

- 1 Operate the external VTR and set it to recording paused status.
- 2 Press the VTR START button of the unit or the VTR button of the lens. The internal and external VTRs start recording simultaneously. Pressing the button again sets both VTRs to the recording paused status.

If One VTR Comes to the End of its Tape During Recording

Even if one VTR comes to the end of its tape and stops, the other VTR continues recording operation.

Returning the VTRs to simultaneous recording status

- If the internal VTR came to the end of its tape, replace the cassette and press the VTR START button of the unit or the VTR button of the lens. The external VTR continues recording operation during this time.
- If the external VTR came to the end of its tape, replace the cassette and operate the external VTR to restart recording. The internal VTR continues recording operation during this time.

<Note>

Care should be taken as the internal VTR will assume recording paused status if the VTR START button of the unit or the VTR button of the lens is pressed after replacing the external VTR's cassette.

Functions of the Unit's VTR SAVE/STBY Switch

Tape running mode

Pressing the unit's STOP, REW or FF buttons sets the internal VTR to stop, rewind or fast forward modes, respectively. However, the external VTR is set to recording paused status in all cases.

Viewing playback images on the viewfinder

Pressing the unit's PLAY button allows black-and-white playback images from the internal VTR tape to be viewed on the viewfinder. Playback images from the external VTR cannot be viewed.

Recording With an External VTR Instead of the Internal VTR

Using the 26-pin/12-pin Output Adaptor

Connections

The method of connecting the external VTR is the same as that described in "Recording Simultaneously with the Internal VTR and an External VTR".

- See "Connections" on page 95.

Mounting the 26-pin/12-pin output adaptor

- Consult your local dealer when mounting the adaptor.

- 1 Set the unit's internal switches.
 - 1 Remove the side panel on the display window side.
 - 2 Remove the Printed Circuit Board holder and remove the CAMERA ENC (4) Printed Circuit Board.
 - 3 Set SW201 to the ON side.
 - 4 To set the audio level to -20 dB, set the SW4701 DIP switch accordingly.

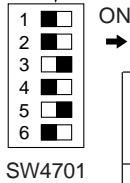
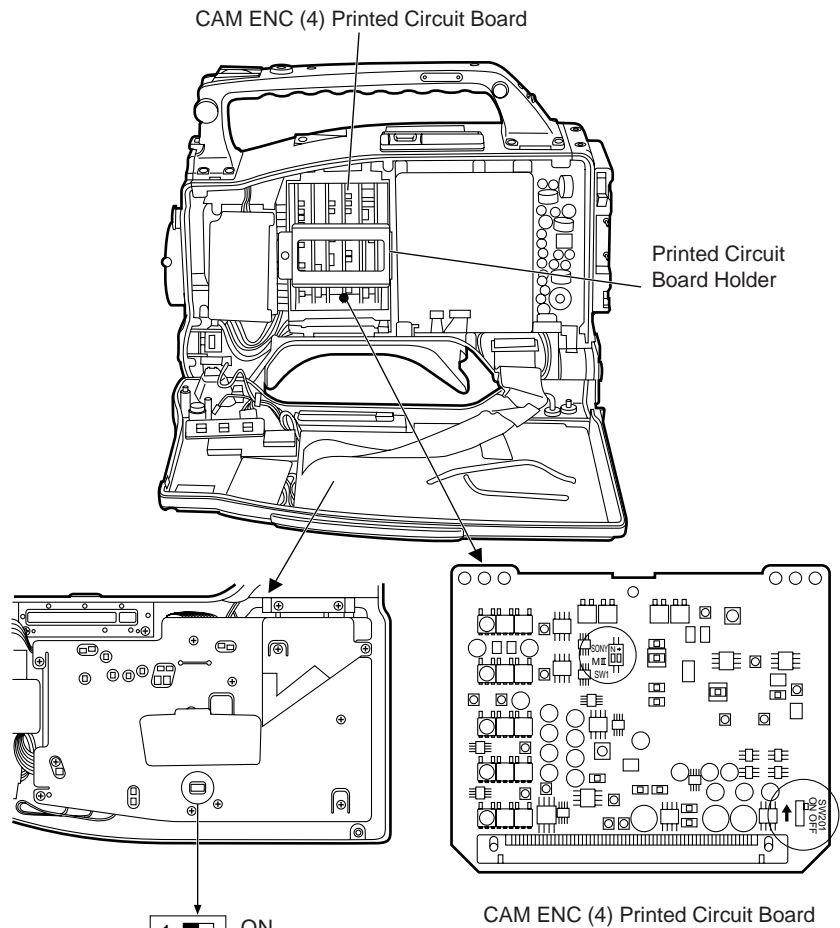

Pin No.	-60 dB (default setting)	-20 dB
1	Not used	
2	ON (NR ON/OFF)	
3	ON	OFF
4	OFF	ON
5	ON	OFF
6	OFF	ON

2 Mount the 26-pin/12-pin output adaptor.

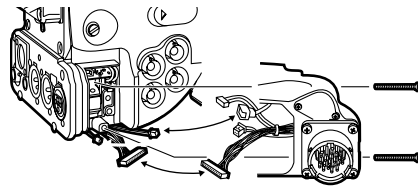

Controlling the external VTR with the unit's switches

Setting the 26P CONTROL function as indicated below at the FUNCTION 3/5 page of the setting menu prevents the internal VTR from being operated and enables only the external VTR to be controlled by the VTR START button of the unit or the VTR button of the lens.

- 26P CONTROL: ON

- See "Selecting Functions" (page 65) for a description of FUNCTION 3/5 page operations.

Switching from the internal VTR to the external VTR

If the internal VTR experiences problems (tapes becoming tangled, condensation, etc.) during operation and becomes unable to operate, the VTR START button of the unit and the VTR button of the lens will not function. In these cases, setting the 26P CONTROL function as noted above at the FUNCTION 3/5 page allows the external VTR to be operated in place of the internal VTR using the VTR START button of the unit or the VTR button of the lens.

Starting recording

Operate the external VTR to set it to recording paused status and press the VTR START button of the unit or the VTR button of the lens. The external VTR starts recording. Pressing the button again sets the VTR to the recording paused status.

Output level of the 26-pin/12-pin output adaptor

The output level factory settings are -60 dBu/balanced for audio and SONY level for component video. When the built-in SW4701 switch is set, the audio output level can be changed to -20 dBu/unbalanced, and when both 1 and 2 of SW1 are set to ON, the component video output level can be changed to the MII level. (See previous page)

RET Button

The images recorded on the VTR or return video signal which has been input from an external source can be seen on the viewfinder screen when the RET (return) button is pressed or while it is kept pressed in.

What appears on the viewfinder screen differs as shown in the table below depending on the RET SW setting for setting menu MAIN FUNCTION and the VTR status.

■ Lens RET button functions

RET switch setting	Internal VTR mode	Description of what appears on viewfinder screen
REC CHECK	Recording	Images shot by camera. RET button does not function.
	Recording paused	What has been recorded (2-second rec review) can be checked.
	Playing	Internal VTR's playback images. RET button does not function.
	Playback paused	Search operation for successive shooting.
CAM RET*	Recording	Return video signal which has been input from an external source.
	Recording paused	Return video signal which has been input from an external source.
	Playing	Return video signal which has been input from an external source.
	Playback paused	Return video signal which has been input from an external source.

*This function can be operated only when this unit is connected with the peripheral devices.

Replacing the Backup Battery

The unit is shipped from the factory with a backup battery already mounted. When the battery runs out, the TCG time code value indicates 00:00:00:00. At this time, the time code value cannot be backed up. In addition, the “BACK UP BATT EMPTY” display appears in the viewfinder for 3 seconds when the POWER switch is set to ON to indicate that the battery must be replaced. Consult your dealer when replacing the battery.

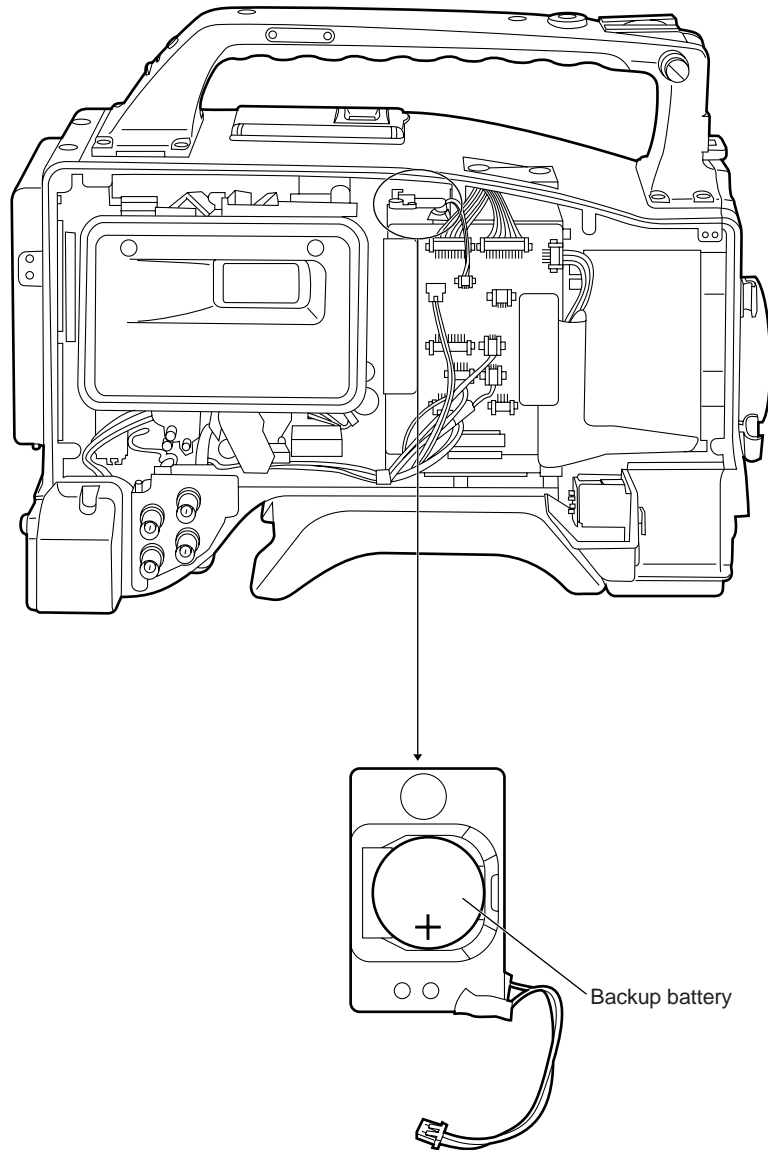

Setting Menu Screens

MARKER Screen

This page sets the setting for the marker displays inside the viewfinder.

- MARKER -
→CENTER MARK : ON SAFETY ZONE : 1

Item	Variable range	VF display	Remarks
CENTER MARK	<u>ON</u> OFF	USER ENG	Center mark display ON/OFF
SAFETY ZONE	OFF <u>1</u> -6	USER ENG	Safety zone switching/display OFF

The underlined setting in the Variable range column indicates the preset mode.

Menu screen display methods

USER menu: Setting the MENU switch to SET displays the USER menu.

ENG menu: Holding down the SHIFT/ITEM and UP buttons simultaneously and setting the MENU switch to SET displays the ENG menu.

VF DISPLAY Screen

This page sets the setting for the display information inside the viewfinder.

- VF DISPLAY -	
-DISP MODE	: 3
EXTENDER	: ON
SHUTTER	: ON
TAPE	: ON
BATTERY	: ON
FILTER	: ON
WHITE	: ON
GAIN	: ON
LEVEL METER	: CH1
IRIS	: S+IRIS
CAMERA ID	: OFF

Menu screen display methods

USER menu: Setting the MENU switch to SET displays the USER menu.

ENG menu: Holding down the SHIFT/ITEM and UP buttons simultaneously and setting the MENU switch to SET displays the ENG menu.

Item	Variable range	VF display	Remarks			
			Change	Display		
				1	2	3
DISP MODE	1- <u>3</u>	USER ENG	FILTER	×	×	○
			GAIN	×	×	○
			AWB	×	×	○
			AUTO KNEE SW	×	○	○
			SHUTTER	×	○	○
			ABB ATATUS	×	○	○
			AWB STATUS	×	○	○
EXTENDER	<u>ON</u> OFF	USER ENG	Extender display ON/OFF			
SHUTTER	<u>ON</u> OFF	USER ENG	Shutter speed display ON/OFF			
TAPE	<u>ON</u> OFF	USER ENG	Remaining tape length display ON/OFF			
BATTERY	<u>ON</u> OFF	USER ENG	Battery voltage display ON/OFF			
FILTER	<u>ON</u> OFF	USER ENG	Filter No. display ON/OFF			
WHITE	<u>ON</u> OFF	USER ENG	AWB PRE/A/B display ON/OFF			
GAIN	<u>ON</u> OFF	USER ENG	Currently selected gain display ON/OFF			
LEVEL METER	<u>CH1</u> CH1 • CH2 OFF	USER ENG	Audio level meter display selection. CH1: The meter displays only the CH1 signal level. CH1 • CH2: The meter displays both the CH1 and CH2 signal levels. OFF: No display			
IRIS	IRIS <u>S+IRIS</u> S OFF	USER ENG	IRIS: Only the f-number is displayed. S+IRIS: Both the super iris ON status and f-number are displayed. S: Only the super iris ON status is displayed. OFF: Neither the super iris ON status nor f-number is displayed.			
CAMERA ID	<u>ON</u> OFF	USER ENG	ID mixing ON/OFF during color bar recording			

The underlined setting in the Variable range column indicates the preset mode.

Setting Menu Screens

CAMERA ID Screen

This page performs the camera ID settings. Each time the UP button is pressed, the character display changes in the order of space, English letters (A to Z), numbers (0 to 9) and symbols [space, >, <,), (, ', ' , ,, --, _ , ~, /, !]. Pressing the DOWN button changes the character display in the reverse order.

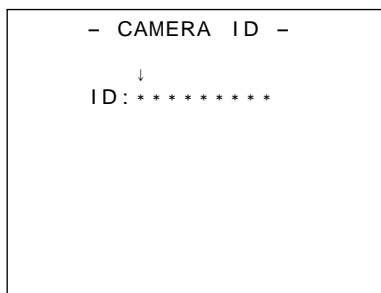

Item	Variable range	VF display	Remarks
ID: *****	—	USER ENG	Camera ID input

<Note>

Whether or not this set value is to be mixed is selected by setting CAMERA ID on the VF DISPLAY screen to ON or OFF.

SHUTTER SPEED Screen

This page performs the shutter speed settings. The ON/OFF status for each item is indicated by displaying an asterisk (*) or period (·) in front of the item on the screen.

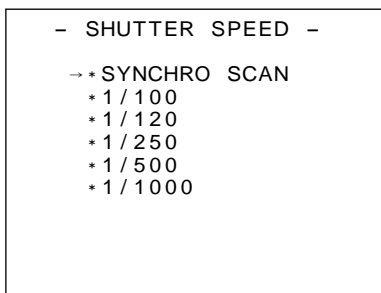

*: ON
·: OFF

Item	Variable range	VF display	Remarks
SYNCHRO SCAN	<u>ON</u> OFF	ENG	Synchro scan shutter speed setting
1/100	<u>ON</u> OFF	ENG	Shutter speed 1/100 setting ON/OFF
1/120	<u>ON</u> OFF	ENG	Shutter speed 1/120 setting ON/OFF
1/250	<u>ON</u> OFF	ENG	Shutter speed 1/250 setting ON/OFF
1/500	<u>ON</u> OFF	ENG	Shutter speed 1/500 setting ON/OFF
1/1000	<u>ON</u> OFF	ENG	Shutter speed 1/1000 setting ON/OFF

<Note>

The SUPER V mode setting is linked to the FUNCTION 2/5 menu setting.

The underlined setting in the Variable range column indicates the preset mode.

Menu screen display methods

USER menu: Setting the MENU switch to SET displays the USER menu.

ENG menu: Holding down the SHIFT/ITEM and UP buttons simultaneously and setting the MENU switch to SET displays the ENG menu.

SYNCHRO SCAN Screen

This page performs the synchro scan settings.

- SYNCHRO SCAN - 1 / 63 . 2

Item	Variable range	VF display	Remarks
SYNCHRO SCAN	<u>1/63.2</u> 1/201.9	USER ENG	Synchro shutter speed selection

! LED Screen

This page sets the ON/OFF setting for the ! LED display inside the viewfinder. The ON/OFF status for each item is indicated by displaying an asterisk (*) or period (·) in front of the item on the screen.

- !LED - → *GAIN (0dB) ·GAIN (-3dB) *SHUTTER ·WHITE PRESET *EXTENDER ·FILTER
--

*: ON
·: OFF

Item	Variable range	VF display	Remarks
GAIN (0 dB)	<u>ON</u> OFF	ENG	This selects whether or not the LED is lighted when the gain is any value other than 0 dB.
GAIN (-3 dB)	ON <u>OFF</u>	ENG	This selects whether or not the LED is lighted when the gain is any value other than -3 dB.
SHUTTER	<u>ON</u> OFF	ENG	This selects whether or not the LED is lighted when the shutter is ON.
WHITE PRESET	ON <u>OFF</u>	ENG	This selects whether or not the LED is lighted when the AWB CH is PRESET.
EXTENDER	<u>ON</u> OFF	ENG	This selects whether or not the LED is lighted when the lens is in EXTENDER mode.
FILTER	ON <u>OFF</u>	ENG	This selects whether or not the LED is lighted when the filter is any value other than 3200K.

<Note>

The ! LED lights when both GAIN (0 dB) and GAIN (-3 dB) are ON unless the gain is set to -3 dB or 0 dB.

The underlined setting in the Variable range column indicates the preset mode.

Menu screen display methods

USER menu: Setting the MENU switch to SET displays the USER menu.

ENG menu: Holding down the SHIFT/ITEM and UP buttons simultaneously and setting the MENU switch to SET displays the ENG menu.

Setting Menu Screens

SET UP CARD Screen

This page sets the loading, saving and formatting operations for setup cards. Align the ">" with the desired item and press the UP or DOWN button to perform the corresponding processing.

Item
READ (> CAM)
WRITE (> CARD)
CARD CONFIG.
ID READ/WRITE
FUNC1~2 R/W

*For example, so as not to change the CAMERA ID when reading from, or writing to the SET UP CARD, the ID READ/WRITE should be selected to OFF.

The underlined setting in the Variable range column indicates the preset mode.

Menu screen display methods

USER menu: Setting the MENU switch to SET displays the USER menu.

ENG menu: Holding down the SHIFT/ITEM and UP buttons simultaneously and setting the MENU switch to SET displays the ENG menu.

MAIN FUNCTION Screen

This page performs the adjustment function settings.

- MAIN FUNCTION -	
→REC MODE	: 16*9/P
PB MODE	: AUTO
RET SW	: REC CHECK

Item	Variable range	VF display	Remarks
REC.MODE	<u>16*9/P</u> 4*3/P 16*9/50I 4*3/50I 16*9/25I 4*3/25I	ENG	The mode for recording the signals onto the VTR is selected. 16*9/P: 525P (16:9) signals are recorded at 50 Mbps. 4*3/P: 525P (4:3) signals are recorded at 50 Mbps. 16*9/50I: 525I (16:9) signals are recorded at 50 Mbps. 4*3/50I: 525I (4:3) signals are recorded at 50 Mbps. 16*9/25I: 525I (16:9) signals are recorded at 25 Mbps. 4*3/25I: 525I (4:3) signals are recorded at 25 Mbps.
PB MODE	AUTO <u>P</u> 50I 25I	ENG	The playback mode is selected. AUTO: The recording mode is automatically detected, and the recording is played back in the mode detected. P: Progressive mode. 50I: 50M (interlace) mode. 25I: 25M (interlace) mode.
RET SW	<u>REC CHECK</u> CAM RET	ENG	This selects the RET SW function. REC CHECK: The REC CHECK operation is performed. CAM RET: The return signal output operation is performed.

BATT/TAPE ALARM Screen

The battery end and tape end audio warnings during shooting can be switched off if they become undesirable.

- BATT/TAPE ALARM -	
→BATT NEAR END	:OFF
BATT END	:ON
TAPE NEAR END	:OFF
TAPE END	:ON

Item	Variable range	VF display	Remarks
BATT NEAR END	ON <u>OFF</u>	ENG	Battery near end audio ON/OFF
BATT END	<u>ON</u> OFF	ENG	Battery end audio warning ON/OFF
TAPE NEAR END	ON <u>OFF</u>	ENG	Tape near end audio warning ON/OFF (A warning is given 3 minutes before the tape end.)
TAPE END	<u>ON</u> OFF	ENG	Tape end audio warning ON/OFF

The underlined setting in the Variable range column indicates the preset mode.

Menu screen display methods

USER menu: Setting the MENU switch to SET displays the USER menu.

ENG menu: Holding down the SHIFT/ITEM and UP buttons simultaneously and setting the MENU switch to SET displays the ENG menu.

Setting Menu Screens

FUNCTION 1/5 Screen

This page performs the adjustment function 1 settings. The ON/OFF status for each item is indicated by displaying an asterix (*) or period (·) in front of the item on the screen.

- FUNCTION 1 / 5 -
→ *DETAIL
· 2D LPF
*MATRIX
*SUPER COLOR
*GAMMA
· TEST SAW
* FLARE
*H-F COMPE.

*: ON
·: OFF

Item	Variable range	VF display	Remarks
DETAIL	<u>ON</u> OFF	ENG	Detail (H, V) ON/OFF switching (ON or OFF for both H and V together)
2D LPF	ON <u>OFF</u>	ENG	ON/OFF switching for 2-dimensional LPF (Low Pass Filter) which reduces color smear
MATRIX	ON <u>OFF</u>	ENG	Color adjustment ON/OFF switching
SUPER COLOR	<u>ON</u> OFF	ENG	ON/OFF switching of the mode for expanding the dynamic range of the colors. Colors above the knee point are boosted.
GAMMA	<u>ON</u> OFF	ENG	Gamma circuit ON/OFF switching
TEST SAW	ON <u>OFF</u>	ENG	Test signal ON/OFF switching
FLARE	<u>ON</u> OFF	ENG	Flare compensation ON/OFF switching
H-F COMPE.	<u>ON</u> OFF	ENG	ON/OFF switching of the mode for increasing the detail in the high range.

FUNCTION 2/5 Screen

This page performs the adjustment function 2 settings.

- FUNCTION 2 / 5 -
→ FILTER INH :OFF
SHOCKLESS AWB :NORMAL
COLOR BARS :SNG
S.GAIN OFF :L/M/H
S.IRIS INH :OFF

The underlined setting in the Variable range column indicates the preset mode.

Menu screen display methods

USER menu: Setting the MENU switch to SET displays the USER menu.

ENG menu: Holding down the SHIFT/ITEM and UP buttons simultaneously and setting the MENU switch to SET displays the ENG menu.

Item	Variable range	VF display	Remarks
FILTER INH	ON <u>OFF</u>	ENG	Switch that determines whether AWB memory (Ach, Bch) data is stored for each filter. ON: Ach and Bch memory only (2 memory units), regardless of the filter. OFF: Data is stored for each filter. (4×2=8 memory units)
SHOCKLESS AWB	OFF <u>NORMAL</u> SLOW FAST	ENG	Shockless AWB ON (NORMAL/SLOW/FAST)/OFF switching. SHOCKLESS AWB ensures that no shock will occur when A/B/PRST setting of the WHITE BAL switch is changed. FAST (high speed), NORMAL (normal speed) or SLOW (low speed) can be set as the selection time.
COLOR BARS	<u>SMPTE</u> SNG	ENG	SMPTE: SMPTE color bar. SNG: SNG (split) color bar.
S.GAIN OFF	S.GAIN <u>L/M/H</u>	ENG	Selection method for releasing the super gain mode. S.GAIN: This mode is released using the SUPER GAIN switch only. L/M/H: This mode is released by changing the L/M/H switch setting.
S.IRIS INH	ON <u>OFF</u>	ENG	This is used to select the super iris function. ON: The super iris function is disabled. OFF: The super iris function is enabled.

FUNCTION 3/5 Screen

This page performs the adjustment function 3 settings.

- FUNCTION 3/5 -	
→HUMID OPE	:OFF
26P CONTROL	:OFF
REC START	:NORMAL
TC MODE	:DF
UB MODE	:USER
PAUSE TIMER	:30
BATTERY SEL	:NiCd-12
TCG VF DISP	:OFF
TCG SET HOLD	:OFF

Item	Variable range	VF display	Remarks
HUMID OPE	ON OFF	ENG	VTR operation selection when condensation occurs. ON: Operation continues normally. OFF: All operations prohibited except for POWER switch and EJECT button.
26P CONTROL	OFF BOTH ON	ENG	26P remote control selection OFF: Unit only (26P control does not function.) BOTH: Unit and 26P remote control (TALLY LED indicates unit REC status.) ON: 26P remote control only (TALLY LED indicates 26P VTR REC status.)
REC START	ALL NORMAL	ENG	REC acceptance selection for VTR START/STOP ALL: REC accepted regardless of VTR mode. NORMAL: REC accepted only during STOP (POWER SAVE) mode and REC PAUSE mode.
TC MODE	DF NDF	ENG	Time code DF/NDF switching DF: Drop frame mode NDF: Non-drop frame mode
UB MODE	USER REAL EXT	ENG	LTC UB usage method selection USER: User setting (fixed value) REAL: Real-time operation according to the TIME DATE time EXT: When there is external TC input, the UBG value is slave locked. (When there is no external input, the user setting is used.)
PAUSE TIMER	10 20 30	ENG	Selection for the recording/pause hold time. 10: 10 minutes 20: 20 minutes 30: 30 minutes
BATTERY SEL	NiCd-12 NiCd-13 NiCd-14 DIGITAL	ENG	Battery type selectionF NiCd-12: 12 V Nicad battery NiCd-13: 13 V Nicad battery NiCd-14: 14 V Nicad battery DIGITAL: Digital battery
TCG VF DISP	ON OFF	ENG	Viewfinder time code display ON/OFF ON: Time code is displayed. OFF: Time code is not displayed.
TCG SET HOLD	ON OFF	ENG	TCG operation selection when TCG SET > power OFF > power ON > REC is selected. ON: The fact that TCG SET has been selected is stored in the memory when the power is switched off, and regeneration is not performed. OFF: Regeneration is performed without storing the fact that TCG SET has been selected in the memory when the power is switched off.

<Notes>

- Set SW201 on the CAM ENC board to ON when 26P CONTROL is to be used.
- Change the time on the TIME/DATE menu screen when the REAL setting is used for UB MODE.

*Even if the BATTERY SEL is selected to NiCd-12, 13 or 14, the camera automatically senses whether or not an Anton Bauer's Intelligent Battery is fitted. In the case of an intelligent battery, a numerical indication (percentage) of power available is displayed in the viewfinder. If the camera is usually used with an intelligent battery, BATTERY SEL should be set to DIGITAL.

Setting Menu Screens

FUNCTION 4/5 Screen

This page performs the adjustment function 4 settings.

- FUNCTION 4/5 -	
→FRONT POWER	: ON
FRONT MIC	: -40dB
REAR MIC CH1	: -60dB
REAR MIC CH2	: -60dB
LINE CH1/CH2	: +4dB
REAR AUDIO	: STEREO
MIC LOWCUT CH1	: ON
MIC LOWCUT CH2	: ON
EMPHASIS	: OFF
LIMITER	: OFF
TEST TONE	: NORMAL

Item	Variable range	VF display	Remarks
FRONT POWER	<u>ON</u> OFF	ENG	ON: The phantom power is supplied to the front microphone. OFF: The phantom power is not supplied to the front microphone.
FRONT MIC	-40/ -50/ -60 dB	ENG	Camera microphone input level selection
REAR MIC CH1	-40/ -50/ -60 dB	ENG	Rear jack AUDIO CH1 input microphone level selection
REAR MIC CH2	-40/ -50/ -60 dB	ENG	Rear jack AUDIO CH2 input microphone level selection
LINE CH1/CH2	+4/0/ -6 dB	ENG	Rear jack AUDIO CH1/CH2 input line input level selection
REAR AUDIO	<u>STEREO</u> MONO	ENG	Audio CH1/CH2 rear jack input selection STEREO: Selects stereo input (CH1 input is recorded in CH1 and CH2 input is recorded in CH2.) MONO: Selects monaural input (The signals of CH1 and CH2 are mixed and recorded in CH1 and CH2 respectively.)
MIC LOWCUT CH1	<u>ON</u> OFF	ENG	CH1 INPUT high-pass filter ON/OFF switching
MIC LOWCUT CH2	<u>ON</u> OFF	ENG	CH2 INPUT high-pass filter ON/OFF switching
EMPHASIS	ON <u>OFF</u>	ENG	Emphasis ON/OFF switching during recording. The EE output signals are also linked with the setting of this switch.
LIMITER	ON <u>OFF</u>	ENG	Audio limiter ON/OFF switching ON: The limiter functions. OFF: The limiter does not function.
TEST TONE	<u>NORMAL</u> ALL	ENG	NORMAL: The TEST TONE signal is output when the CAM/BAR switch is set to BAR and the AUDIO IN switch CH1 is set to FRONT. ALL: The TEST TONE signal is output when the CAM/BAR switch is set to BAR.

<Notes>

- The frequency response for MIC LOWCUT ON are 200 Hz to 10 kHz.
- LIMITER initiates the limiter operation at a level equivalent to 3 dB below the peak (+18 dB).
- AUDIO SELECT initiates the limiter operation at the MAN setting and the AGC operation at the AUTO setting.

The underlined setting in the Variable range column indicates the preset mode.

Menu screen display methods

USER menu: Setting the MENU switch to SET displays the USER menu.

ENG menu: Holding down the SHIFT/ITEM and UP buttons simultaneously and setting the MENU switch to SET displays the ENG menu.

FUNCTION 5/5 Screen

This page performs the adjustment function 5 settings.

- FUNCTION 5/5 -
->VIDEO OUT :MENU ON

Item	Variable range	VF display	Remarks
VIDEO OUT	<u>MENU</u> ON MENU OFF	ENG	This is for selecting whether characters are to be displayed for the VIDEO OUT signals. MENU ON: Characters are displayed. MENU OFF: Characters are not displayed.

The underlined setting in the Variable range column indicates the preset mode.

Menu screen display methods

USER menu: Setting the MENU switch to SET displays the USER menu.

ENG menu: Holding down the SHIFT/ITEM and UP buttons simultaneously and setting the MENU switch to SET displays the ENG menu.

Setting Menu Screens

LOW SETTING Screen

This page sets the low level.

```

- LOW SETTING (16*9/P) -
  -MASTER GAIN : 0dB
    H.DTL LEVEL : 12
    V.DTL LEVEL : 14
    DTL CORING  : 02
    H.DTL FREQ. : 04
    V.DTL FREQ. : P
    DARK DTL    : 00
    LEVEL DEPEND : 01
    MASTER GAMMA : 0.45
    BLACK STRETCH : OFF
    MATRIX TABLE : A
  
```

(What appears inside the parentheses at the top right indicates the camera mode.)

This menu enables the 4 modes (16*9/P, 4*3/P, 16*9/I and 4*3/I) of the camera to be set separately. (However, the MASTER GAIN and MASTER GAMMA settings are common to all the modes.)

<Note>

DARK DTL and LEVEL DEPEND function in a mutually opposite way: LEVEL DEPEND is automatically set to 0 when DARK DTL is set to a value other than 0; and DARK DTL is automatically set to 0 when LEVEL DEPEND is set to a value other than 0.

The underlined setting in the Variable range column indicates the preset mode.

Menu screen display methods

USER menu: Setting the MENU switch to SET displays the USER menu.

ENG menu: Holding down the SHIFT/ITEM and UP buttons simultaneously and setting the MENU switch to SET displays the ENG menu.

Item	Variable range	VF display	Remarks
MASTER GAIN	-3 dB ⋮ <u>0</u> dB ⋮ 30 dB	ENG	Gains of -3, 0, 3, 6, 9, 12, 15, 18, 21, 24 and 30 dB can be set.
H.DTL LEVEL	0 ⋮ <u>12</u> ⋮ 31	ENG	H.DTL (detail) level setting
V.DTL LEVEL	0 ⋮ <u>14</u> ⋮ 31	ENG	V.DTL (detail) level setting
DTL CORING	0 ⋮ <u>2</u> ⋮ 15	ENG	DTL coring setting
H.DTL FREQ.	1 ⋮ <u>4</u> ⋮ 5	ENG	H.DTL frequency selection 1: 2.5 MHz 4: 4 MHz 2: 3 MHz 5: 4.5 MHz 3: 3.5 MHz
V.DTL FREQ.	<u>P</u> PIMIX I	ENG	V.DTL frequency selection P: The frequency is suited to the progressive mode. PIMIX: The progressive and interlace frequencies are mixed. I: The frequency is suited to the interlace mode.
DARK DTL	<u>0</u> -5	ENG	Dark detail setting It boosts the detail of the black areas.
LEVEL DEPEND.	0 <u>1</u> ⋮ 5	ENG	LEVEL DEPEND. setting It eliminates the detail only in the dark areas when the Y detail is boosted. The higher the number selected, the wider the range across which the detail is eliminated.
MASTER GAMMA	0.35 ⋮ <u>0.45</u> ⋮ 0.75	ENG	Master gamma setting 0.01 steps
BLACK STRETCH	ON <u>OFF</u>	ENG	ON/OFF switching for mode which compensates low-illumination black-out
MATRIX TABLE	<u>A</u> B	ENG	Color compensation table selection

MID SETTING Screen

This page sets the middle level.

```

- MID SETTING(16*9/P) -
  -MASTER GAIN : 9dB
  H.DTL LEVEL  : 12
  V.DTL LEVEL  : 14
  DTL CORING   : 04
  H.DTL FREQ.  : 04
  V.DTL FREQ.  : P
  DARK DTL     : 00
  LEVEL DEPEND : 03
  MASTER GAMMA : 0.45
  BLACK STRETCH: OFF
  MATRIX TABLE: A
    
```

(What appears inside the parentheses at the top right indicates the camera mode.)

This menu enables the 4 modes (16*9/P, 4*3/P, 16*9/I and 4*3/I) of the camera to be set separately. (However, the MASTER GAIN and MASTER GAMMA settings are common to all the modes.)

<Note>

DARK DTL and LEVEL DEPEND function in a mutually opposite way: LEVEL DEPEND is automatically set to 0 when DARK DTL is set to a value other than 0; and DARK DTL is automatically set to 0 when LEVEL DEPEND is set to a value other than 0.

The underlined setting in the Variable range column indicates the preset mode.

Menu screen display methods

USER menu: Setting the MENU switch to SET displays the USER menu.

ENG menu: Holding down the SHIFT/ITEM and UP buttons simultaneously and setting the MENU switch to SET displays the ENG menu.

Item	Variable range	VF display	Remarks
MASTER GAIN	-3 dB ⋮ <u>9</u> dB ⋮ 30 dB	ENG	Gains of -3, 0, 3, 6, 9, 12, 15, 18, 21, 24 and 30 dB can be set.
H.DTL LEVEL	0 ⋮ <u>12</u> ⋮ 31	ENG	H.DTL (detail) level setting
V.DTL LEVEL	0 ⋮ <u>14</u> ⋮ 31	ENG	V.DTL (detail) level setting
DTL CORING	0 ⋮ <u>4</u> ⋮ 15	ENG	DTL coring setting
H.DTL FREQ.	1 ⋮ <u>4</u> ⋮ 5	ENG	H.DTL frequency selection 1: 2.5 MHz 4: 4 MHz 2: 3 MHz 5: 4.5 MHz 3: 3.5 MHz
V.DTL FREQ.	<u>P</u> PIMIX I	ENG	V.DTL frequency selection P: The frequency is suited to the progressive mode. PIMIX: The progressive and interlace frequencies are mixed. I: The frequency is suited to the interlace mode.
DARK DTL	<u>0</u> -5	ENG	Dark detail setting It boosts the detail of the black areas.
LEVEL DEPEND.	0 ⋮ <u>3</u> ⋮ 5	ENG	LEVEL DEPEND. setting It eliminates the detail only in the dark areas when the Y detail is boosted. The higher the number selected, the wider the range across which the detail is eliminated.
MASTER GAMMA	0.35 ⋮ <u>0.45</u> ⋮ 0.75	ENG	Master gamma setting 0.01 steps
BLACK STRETCH	ON <u>OFF</u>	ENG	ON/OFF switching for mode which compensates low-illumination black-out
MATRIX TABLE	<u>A</u> B	ENG	Color compensation table selection

Setting Menu Screens

HIGH SETTING Screen

This page sets the high level.

- HIGH SETTING (16*9/P) -	
-MASTER GAIN	:18dB
H.DTL LEVEL	:12
V.DTL LEVEL	:10
DTL CORING	:10
H.DTL FREQ.	:04
V.DTL FREQ.	:P
DARK DTL	:00
LEVEL DEPEND	:04
MASTER GAMMA	:0.55
BLACK STRETCH	:OFF
MATRIX TABLE	:A

(What appears inside the parentheses at the top right indicates the camera mode.)

This menu enables the 4 modes (16*9/P, 4*3/P, 16*9/I and 4*3/I) of the camera to be set separately. (However, the MASTER GAIN and MASTER GAMMA settings are common to all the modes.)

Item	Variable range	VF display	Remarks
MASTER GAIN	-3 dB ⋮ <u>18</u> dB ⋮ 30 dB	ENG	Gains of -3, 0, 3, 6, 9, 12, 15, 18, 21, 24 and 30 dB can be set.
H.DTL LEVEL	0 ⋮ <u>12</u> ⋮ 31	ENG	H.DTL (detail) level setting
V.DTL LEVEL	0 ⋮ <u>10</u> ⋮ 31	ENG	V.DTL (detail) level setting
DTL CORING	0 ⋮ <u>10</u> ⋮ 15	ENG	DTL coring setting
H.DTL FREQ.	1 ⋮ <u>4</u> ⋮ 5	ENG	H.DTL frequency selection 1: 2.5 MHz 4: 4 MHz 2: 3 MHz 5: 4.5 MHz 3: 3.5 MHz
V.DTL FREQ.	P PIMIX I	ENG	V.DTL frequency selection P : The frequency is suited to the progressive mode. PIMIX : The progressive and interlace frequencies are mixed. I : The frequency is suited to the interlace mode.
DARK DTL	<u>0</u> -5	ENG	Dark detail setting It boosts the detail of the black areas.
LEVEL DEPEND.	0- <u>4</u> -5	ENG	LEVEL DEPEND. setting
MASTER GAMMA	0.35 ⋮ <u>0.55</u> ⋮ 0.75	ENG	LEVEL DEPEND. setting It eliminates the detail only in the dark areas when the Y detail is boosted. The higher the number selected, the wider the range across which the detail is eliminated.
BLACK STRETCH	ON <u>OFF</u>	ENG	ON/OFF switching for mode which compensates low-illumination black-out
MATRIX TABLE	A B	ENG	Color compensation table selection

<Note>

DARK DTL and LEVEL DEPEND function in a mutually opposite way: LEVEL DEPEND is automatically set to 0 when DARK DTL is set to a value other than 0; and DARK DTL is automatically set to 0 when LEVEL DEPEND is set to a value other than 0.

The underlined setting in the Variable range column indicates the preset mode.

Menu screen display methods

USER menu: Setting the MENU switch to SET displays the USER menu.

ENG menu: Holding down the SHIFT/ITEM and UP buttons simultaneously and setting the MENU switch to SET displays the ENG menu.

LEVEL 1/6 Screen

This page performs the camera setup level 1 settings.

Item	Variable range	VF display	Remarks
C DTL COMPE.	ON OFF	ENG	Chroma DTL ON/OFF switching
CHROMA DTL	0–15	ENG	Chroma DTL setting*
C DTL CORING	0–15	ENG	Chroma DTL CORING setting
KNEE APERTURE	ON OFF	ENG	Knee aperture ON/OFF switching Detail above the knee point is boosted.
SLIM DTL	ON OFF	ENG	ON/OFF switching for mode which narrows detail
CORNER DTL	ON OFF	ENG	ON/OFF switching for mode which increases edge resolution

LEVEL 2/6 Screen

This page performs the camera setup level 2 settings.

Item	Variable range	VF display	Remarks
SKIN TONE DTL	ON OFF	ENG	Skin tone detail ON/OFF switching
SKIN TONE HUE	103 ⋮ 143	ENG	Skin tone hue setting (This sets the phase of the skin tone detection range.) It changes the hue in the phase direction.
SKIN TONE LEVEL	1 ⋮ 25 ⋮ 50	ENG	Skin tone level setting (This sets the intensity of the colors in the skin tone detection range.) It changes the level in the amplitude direction.
SKIN TONE WIDTH	1 ⋮ 15 ⋮ 30	ENG	Skin tone width setting*
SKIN TONE CORING	1–5	ENG	Skin tone coring setting This changes the amount of SKIN TONE range detail.
SKIN TONE ZEBRA	ON OFF	ENG	This sets ZEBRA in the SKIN TONE range to ON or OFF. This changes the coring in the range across which ZEBRA can be seen.

Setting Menu Screens

LEVEL 3/6 Screen

This page performs the camera setup level 3 settings.

- LEVEL 3/6 -	
-M.PED	:+000
SET UP	:7.5%A
MANUAL KNEE	:ON
KNEE POINT	:197
KNEE SLOPE	:18
WHITE CLIP	:ON
WHITE CLIP LVL	:110%

Item	Variable range	VF display	Remarks
M.PED	-100 ⋮ <u>+0</u> ⋮ +100	ENG	M.PED (Master pedestal level) setting
SET UP	0% 7.5% <u>7.5%A</u>	ENG	Setup level switching 0%: 0% setup for both camera output and tape. 7.5%: 7.5% setup for both camera output and tape. 7.5%A: 7.5% setup for camera output; 0% setup for tape. *When the setting is changed to 0% or 7.5%, chroma and burst levels on the CAM ENC board are required to adjust again.
MANUAL KNEE	<u>ON</u> OFF	ENG	Mode setting when AUTO KNEE switch is set to OFF
KNEE POINT	<u>197</u> ⋮ 219	ENG	Manual knee point position setting
KNEE SLOPE	0 ⋮ <u>18</u> ⋮ 25	ENG	Manual knee inclination setting
WHITE CLIP	<u>ON</u> OFF		White clip ON/OFF switching
WHITE CLIP LVL	90% ⋮ <u>110%</u>		White clip level setting

The underlined setting in the Variable range column indicates the preset mode.

Menu screen display methods

USER menu: Setting the MENU switch to SET displays the USER menu.

ENG menu: Holding down the SHIFT/ITEM and UP buttons simultaneously and setting the MENU switch to SET displays the ENG menu.

LEVEL 4/6 Screen

This page performs the camera setup level 4 settings.

- LEVEL 4/6 -
→R FLARE :---
G FLARE :---
B FLARE :---
R GAMMA :+00
B GAMMA :+00

Item	Variable range	VF display	Remarks
R FLARE	00 ⋮ 100	ENG	Rch flare setting The preset value differs according to the camera.
G FLARE	00 ⋮ 100	ENG	Gch flare setting The preset value differs according to the camera.
B FLARE	00 ⋮ 100	ENG	Bch flare setting The preset value differs according to the camera.
R GAMMA	-15 ⋮ <u>+00</u> ⋮ +15	ENG	Rch gamma compensation value for the master gamma.
B GAMMA	-15 ⋮ <u>+00</u> ⋮ +15	ENG	Bch gamma compensation value for the master gamma.

<Note>

The R FLARE, G FLARE and B FLARE will not be initialized even when the initialization (default setting) operation is performed.

The underlined setting in the Variable range column indicates the preset mode.

Menu screen display methods

USER menu: Setting the MENU switch to SET displays the USER menu.

ENG menu: Holding down the SHIFT/ITEM and UP buttons simultaneously and setting the MENU switch to SET displays the ENG menu.

Setting Menu Screens

LEVEL 5/6 Screen

This page performs the camera setup level 5 settings.

- LEVEL 5/6 -	
-MATRIX TABLE	:A
MATRIX R-G	:+00
MATRIX R-B	:+00
MATRIX G-R	:+00
MATRIX G-B	:+00
MATRIX B-R	:+00
MATRIX B-G	:+00

Item	Variable range	VF display	Remarks
MATRIX TABLE	<u>A</u> B	ENG	Color adjustment table selection
MATRIX R-G	-31 ⋮ <u>+0</u> ⋮ +31	ENG	Color adjustment
MATRIX R-B	-31 ⋮ <u>+0</u> ⋮ +31	ENG	Color adjustment
MATRIX G-R	-31 ⋮ <u>+0</u> ⋮ +31	ENG	Color adjustment
MATRIX G-B	-31 ⋮ <u>+0</u> ⋮ +31	ENG	Color adjustment
MATRIX B-R	-31 ⋮ <u>+0</u> ⋮ +31	ENG	Color adjustment
MATRIX B-G	-31 ⋮ <u>+0</u> ⋮ +31	ENG	Color adjustment

<Note>

The white balance and black balance remain unchanged even when the MATRIX items are changed.

The underlined setting in the Variable range column indicates the preset mode.

<Note>

All settings are "00" for the preset mode of MATRIX TABLE B.

Menu screen display methods

USER menu: Setting the MENU switch to SET displays the USER menu.

ENG menu: Holding down the SHIFT/ITEM and UP buttons simultaneously and setting the MENU switch to SET displays the ENG menu.

LEVEL 6/6 Screen

This page performs the camera setup level 6 settings.

- LEVEL 6/6 -	
◦ H PHASE COARSE	: 07
H PHASE FINE	: 128
SC PHASE COARSE	: 0
SC PHASE FINE	: 128
A. IRIS LEVEL	: 072
A. IRIS PEAK/AVE	: 063
A. IRIS MODE	: NORM1
S. IRIS LEVEL	: 075

Item	Variable range	VF display	Remarks
H PHASE COARSE	0 ⋮ <u>7</u> ⋮ 15	ENG	H phase rough adjustment during GENLOCK mode.
H PHASE FINE	0 ⋮ <u>128</u> ⋮ 255	ENG	H phase fine adjustment during GENLOCK mode.
SC PHASE COARSE	0 ⋮ 3	ENG	SC phase rough adjustment during GENLOCK mode.
SC PHASE FINE	0 ⋮ <u>128</u> ⋮ 255	ENG	SC phase fine adjustment during GENLOCK mode.
A. IRIS LEVEL	0 ⋮ <u>72</u> ⋮ 100	ENG	Auto iris target value setting The brightness (iris) is controlled using this value. The higher the number selected, the greater the brightness.
A. IRIS PEAK/AVE.	0 ⋮ <u>63</u> ⋮ 100	ENG	Auto iris peak: average value ratio setting The closer the selected value is to 0, the greater the tendency toward AVE control; the closer the selected value is to 100, the greater the tendency toward PEAK control.
A. IRIS MODE	<u>NORM1</u> NORM2 CENTR	ENG	Auto iris mode selection NORM1 : Light metering over entire screen (except for edges). NORM2 : Light metering over entire screen (except for top). CENTR : The light is measured only at the screen center.
S. IRIS LEVEL	0 ⋮ <u>75</u> ⋮ 100	ENG	Super iris target value setting (Backlight compensation mode)

The underlined setting in the Variable range column indicates the preset mode.

Menu screen display methods

USER menu: Setting the MENU switch to SET displays the USER menu.

ENG menu: Holding down the SHIFT/ITEM and UP buttons simultaneously and setting the MENU switch to SET displays the ENG menu.

Setting Menu Screens

VF OPERATION Screen

This page performs the viewfinder display settings.

- VF OPERATION -	
VF OUT	: Y
VF DTL	: 2
ZEBRA1 DETECT	: 070
ZEBRA2 DETECT	: 085
ZEBRA2	: SPOT

Item	Variable range	VF display	Remarks
VF OUT	<u>Y</u> NAM R G B	ENG	VF OUT selection NAM (N Additive Mix): Signals with the highest level among R, G and B are output.
VF DTL	0 ⋮ <u>2</u> ⋮ 4	ENG	VF DTL selection The detail of the VF signals is further boosted. At the "0" setting, the detail is the same as the main line.
ZEBRA1 DETECT	50 ⋮ <u>70</u> ⋮ 110	ENG	ZEBRA1 DETECT level (IRE value) setting
ZEBRA2 DETECT	50 ⋮ <u>85</u> ⋮ 110	ENG	ZEBRA2 DETECT level (IRE value) setting
ZEBRA2	ON OFF <u>SPOT</u>	ENG	ZEBRA2 ON/OFF switching and SPOT selection ⓘWhen ZEBRA2 is set to SPOT, set the ZEBRA2 DETECT value higher than the ZEBRA1 DETECT value. If the ZEBRA2 DETECT value is less than the ZEBRA1 DETECT value, the ZEBRA pattern will not be displayed.

E: ON
⋮: OFF

The underlined setting in the Variable range column indicates the preset mode.

Menu screen display methods

USER menu: Setting the MENU switch to SET displays the USER menu.

ENG menu: Holding down the SHIFT/ITEM and UP buttons simultaneously and setting the MENU switch to SET displays

TIME DATE Screen

This page performs the date and time settings. After the date and time have been changed, pressing the UP or DOWN buttons executes the settings.

```

- TIME/DATE -
  ◦ YEAR   : 98
    MONTH  : 01
    DAY     : 01
    HOUR    : 00
    MINUTE  : 00
  · TIME/DATE SET
  
```

Item	Variable range	VF display	Remarks
YEAR	<u>98</u> to 10	ENG	Year setting
MONTH	<u>1</u> to 12	ENG	Month setting
DAY	<u>1</u> to 31	ENG	Day setting
HOUR	<u>0</u> to 23	ENG	Hour setting
MINUTE	<u>0</u> to 59	ENG	Minute setting
TIME/DATE SET	—	ENG	Date/time confirmation

Note

The seconds are cannot be set. The time always starts from the zero second setting.

MENU SELECT 1/3 Screen

This page performs the menu page display ON/OFF settings. The ON/OFF status for each item is indicated by displaying an asterisk (E) or period (·) in front of the item on the screen.

```

- MENU SELECT 1/3 -
  ◦ E MARKER
    EVF DISPLAY
    E CAMERA ID
    · SHUTTER SPEED
    E SYNCHRO SCAN
    · !LED
    E SET UP CARD
    · MAIN FUNCTION
    · BATT/TAPE ALARM
  
```

E: ON
·: OFF

Item	Variable range	VF display	Remarks
MARKER	<u>ON</u> OFF	ENG	MARKER item user menu display ON/OFF
VF DISPLAY	<u>ON</u> OFF	ENG	VF DISPLAY item user menu display ON/OFF
CAMERA ID	<u>ON</u> OFF	ENG	CAMERA ID item user menu display ON/OFF
SHUTTER SPEED	ON <u>OFF</u>	ENG	SHUTTER SPEED item user menu display ON/OFF
SYNCHRO SCAN	<u>ON</u> OFF	ENG	SYNCHRO SCAN item user menu display ON/OFF
!LED	ON <u>OFF</u>	ENG	!LED item user menu display ON/OFF
SET UP CARD	<u>ON</u> OFF	ENG	SET UP CARD item user menu display ON/OFF
MAIN FUNCTION	<u>ON</u> OFF	ENG	MAIN FUNCTION item user menu display ON/OFF
BATT/TAPE ALARM	ON <u>OFF</u>	ENG	BATT/TAPE ALARM item user menu display ON/OFF ON: This switches the display ON. OFF: This switches the display OFF.

The underlined setting in the Variable range column indicates the preset mode.

Menu screen display methods

USER menu: Setting the MENU switch to SET displays the USER menu.

ENG menu: Holding down the SHIFT/ITEM and UP buttons simultaneously and setting the MENU switch to SET displays the ENG menu.

Setting Menu Screens

MENU SELECT 2/3 Screen

This page performs the menu page display ON/OFF settings. The ON/OFF status for each item is indicated by displaying an asterisk (E) or period (·) in front of the item on the screen.

- MENU SELECT 2 / 3 -
<ul style="list-style-type: none"> · FUNCTION 1 / 5 · FUNCTION 2 / 5 · FUNCTION 3 / 5 · FUNCTION 4 / 5 · FUNCTION 5 / 5 · LOW SETTING · MID SETTING · HIGH SETTING

E: ON
·: OFF

Item	Variable range	VF display	Remarks
FUNCTION 1/5	ON <u>OFF</u>	ENG	FUNCTION 1/5 item user menu display ON/OFF
FUNCTION 2/5	ON <u>OFF</u>	ENG	FUNCTION 2/5 item user menu display ON/OFF
FUNCTION 3/5	ON <u>OFF</u>	ENG	FUNCTION 3/5 item user menu display ON/OFF
FUNCTION 4/5	ON <u>OFF</u>	ENG	FUNCTION 4/5 item user menu display ON/OFF
FUNCTION 5/5	ON <u>OFF</u>	ENG	FUNCTION 5/5 item user menu display ON/OFF
LOW SETTING	ON <u>OFF</u>	ENG	LOW SETTING item user menu display ON/OFF
MID SETTING	ON <u>OFF</u>	ENG	MID SETTING item user menu display ON/OFF
HIGH SETTING	ON <u>OFF</u>	ENG	HIGH SETTING item user menu display ON/OFF

The underlined setting in the Variable range column indicates the preset mode.

Menu screen display methods

USER menu: Setting the MENU switch to SET displays the USER menu.

ENG menu: Holding down the SHIFT/ITEM and UP buttons simultaneously and setting the MENU switch to SET displays the ENG menu.

MENU SELECT 3/3 Screen

This page performs the menu page display ON/OFF settings. The ON/OFF status for each item is indicated by displaying an asterix (E) or period (·) in front of the item on the screen.

- MENU SELECT 3/3 -
· LEVEL 1/6
· LEVEL 2/6
· LEVEL 3/6
· LEVEL 4/6
· LEVEL 5/6
· LEVEL 6/6
· VF OPERATION
· LENS ADJ
· TIME/DATE

E: ON
·: OFF

Item	Variable range	VF display	Remarks
LEVEL 1/6	ON <u>OFF</u>	ENG	LEVEL 1/6 item user menu display ON/OFF
LEVEL 2/6	ON <u>OFF</u>	ENG	LEVEL 2/6 item user menu display ON/OFF
LEVEL 3/6	ON <u>OFF</u>	ENG	LEVEL 3/6 item user menu display ON/OFF
LEVEL 4/6	ON <u>OFF</u>	ENG	LEVEL 4/6 item user menu display ON/OFF
LEVEL 5/6	ON <u>OFF</u>	ENG	LEVEL 5/6 item user menu display ON/OFF
LEVEL 6/6	ON <u>OFF</u>	ENG	LEVEL 6/6 item user menu display ON/OFF
VF OPERATION	ON <u>OFF</u>	ENG	VF OPERATION item user menu display ON/OFF
LENS ADJ	ON <u>OFF</u>	ENG	LENS ADJ item user menu display ON/OFF
TIME/DATE	ON <u>OFF</u>	ENG	TIME/DATE item user menu display ON/OFF

The underlined setting in the Variable range column indicates the preset mode.

Menu screen display methods

USER menu: Setting the MENU switch to SET displays the USER menu.

ENG menu: Holding down the SHIFT/ITEM and UP buttons simultaneously and setting the MENU switch to SET displays the ENG menu.

Setting Menu Screens

AUTO SHADING Screen

This page performs the auto shading settings. Align the arrow with the desired BLACK or WHITE item and press the UP or DOWN button to execute the setting.

```

- AUTO SHADING -
c BLACK
WHITE (V. SAW)
BLACK COMPE :ON
WHITE COMPE :ON
    
```

Item	Variable range	VF display	Remarks
BLACK	—	ENG	Auto black shading (digital) activated
WHITE (V. SAW)	—	ENG	Auto white shading (V. SAW) activated
BLACK COMPE	<u>ON</u> OFF	ENG	Digital black shading compensation
WHITE COMPE	<u>ON</u> OFF	ENG	Digital white shading compensation

The underlined setting in the Variable range column indicates the preset mode.

DATA RESET Screen

This page resets the menu display item settings. Aligning the cursor (arrow) with the item and pressing the UP or DOWN button resets the settings.

```

- DATA RESET -
c MENU INIT.
    
```

Item	Variable range	VF display	Remarks
MENU INIT.	—	ENG	Sets the setting menu to the status when shipped from the factory.

Note
The flare compensation value (LEVEL 4/6) and shading compensation value (AUTO SHADING) do not return to the default settings.

DIAGNOSTIC Screen

This page displays the unit's operating conditions and software version.

```

- DIAGNOSTIC -
OPERATION :00000 ·10h
DRUM RUNNING:00000 ·10h
THREADING :00000 ·10
VTR SYSCON Ver<1.0>
CAM SYSCON Ver<1.0>
DATA ROM Ver<1.0>
DV Ver<1.0000 >
98.XX.XX
    
```

Item	Variable range	VF display	Remarks
OPERATION	—	ENG	Operating time with the power ON
DRUM RUNNING	—	ENG	Drum rotating time
THREADING	—	—	Loading time
VTR SYSCON	—	ENG	Software version display
CAM SYSCON	—	ENG	Software version display
DATA ROM	—	ENG	Software version display
DV	—	ENG	Software version display

Menu screen display methods

USER menu: Setting the MENU switch to SET displays the USER menu.

ENG menu: Holding down the SHIFT/ITEM and UP buttons simultaneously and setting the MENU switch to SET displays the ENG menu.

Warning System

If trouble is detected immediately after the power is turned on or during operation, the display window (LCD), WARNING lamp, lamps inside the viewfinder, and warning tones from the speaker and earphone inform the operator of trouble.

Item	Display window (LCD)				Lamps		Warning contents
	Warning display	Warning display status	Remaining battery level display	Remaining tape length display	WARNING lamp	REC lamp	
RF							Emitted 4 times per second (F1) Video head clogging, recording system trouble
SERVO							Emitted 4 times per second The servo is out of order.
HUMID							Condensation
SLACK							Tape wind-up trouble

Warning System

Item	Display window (LCD)				Lamps		Warning tone	Warning contents	VTR (section) operation	Countermeasures
	Warning display	Warning display status	Remaining battery level display	Remaining tape length display	WARNING lamp	REC lamp				
TAPE END	E TAPE F	Flashes F1)		1 of the 7 bars displayed; 5-0 display inside the viewfinder flashes	Flashes 1 time per second F1)	Flashes 1 time per second	Emitted 4 times per second	The tape is nearing its end.	Operation continues.	Replace the tape as necessary.
		Flashes		All 7 bars displayed	Lighted	Flashes 4 times per second	Continuous tone	The tape has reached its end.	Recording, playback or fast forward operation stops.	Replace the cassette or rewind the tape.
BATTERY END	E BATT F	Flashes	1 of the 7 bars displayed		Flashes 1 time per second	Flashes 1 time per second	Emitted 4 times per second F1)	The battery has almost run out.	Operation continues.	Replace the battery as necessary.
		Flashes	All 7 bars displayed		Lighted	Flashes 4 times per second	Continuous tone	The battery has run out.	Operation stops.	Replace the battery.

F1) During recording

F2) During playback, fast forward or rewind

Notes

When trouble occurs with the external VTR connected to the unit, warnings are displayed only by the unit's REC and TALLY lamps.

When connecting the external VTR to the 26-pin/12-pin output adaptor and recording simultaneously with the internal and external VTRs, the REC and TALLY lamps flash if trouble occurs in either VTR. Check the warning displays of each VTR to confirm the error contents.

Warning system priorities are as follows.

- 1 SLACK
- 2 BATTERY END
- 3 TAPE END
- 4 BATTERY NEAR END
- 5 TAPE NEAR END
- 6 HUMID
- 7 SERVO
- 8 RF

Emergency eject

If the cassette is not ejected even when the EJECT button is pressed, use a screwdriver or other implement to push down and simultaneously turn the EMERGENCY screw. This will enable the cassette to be ejected.

- 1 Turn off the power of the VTR.
- 2 As shown in the figure, remove the rubber cap, and fit a Phillips head screwdriver into the cross part of the EMERGENCY screw (red).
- 3 While pressing on the screwdriver, continue to turn the EMERGENCY screw in the counter-clockwise direction until the cassette moves up.
- 4 Take out the cassette.
- 5 Return the rubber cap to its original position.

Note

1. Do not turn the EMERGENCY screw unless it is an emergency.
2. Do not turn the screw in the clockwise direction. After the cassette has moved up, do not turn the screw any further. Otherwise, the mechanism may be damaged.
3. After the cassette has moved up, the cassette holder will not lock even when it is closed. Before closing the cassette holder, be absolutely sure to turn the power off and back on again to reset the mechanism's operation.

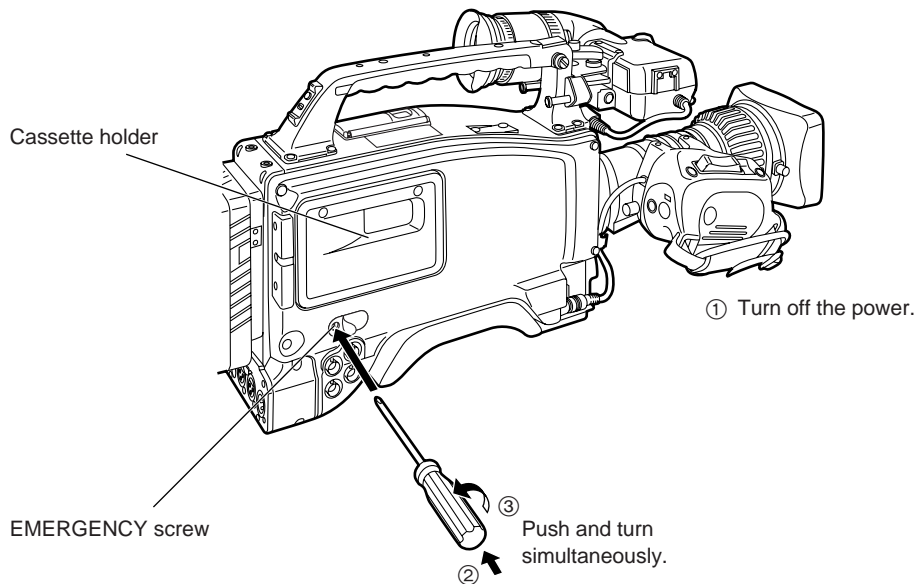

Error Codes

When an error occurs in the unit for some reason or other, the following error codes appear in the display window.

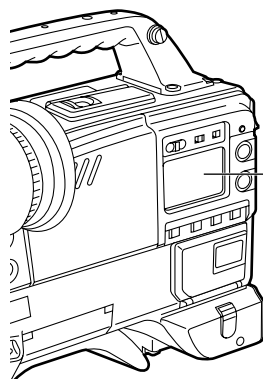

Code No.	Contents
8	Solenoid trouble
9	The servo is not locked.
A	Condensation has occurred.
B	Supply reel trouble
C	Take-up reel trouble
D	Capstan trouble
E	Cylinder trouble
F	Loading trouble

Maintenance

Condensation

If the unit is moved from a cold location to a warm location or used in areas with high humidity, the moisture in the air may adhere as water droplets on the head drum. This is called condensation, and if the tape is run under these conditions, it will easily stick to the drum. Therefore, the following points should be observed.

- ˘ If the unit is moved under conditions where condensation may occur, eject the tape.
- ˘ Before inserting the tape, set the POWER switch to ON and check that the HUMID display in the display window is not lighted. If the HUMID display is lighted, do not insert the tape until the display goes off.

The HUMID display
is not lighted.

Cleaning the Video Heads

Use the AJ-CL12MP cleaning cassette when head cleaning is required. Improper use of the cleaning cassette may damage the video heads. Therefore, read the Handling Instructions for the cleaning tape carefully before use.

Cleaning the Viewfinder

- ˘ Do not use thinner or other solvents to remove dirt from the viewfinder.
- ˘ Wipe the lens with lens cleaner available on the market.
- ˘ Absolutely do not wipe the mirror. If dirt, etc. has adhered to the mirror, remove it using a air blower available on the market.

Characteristic Phenomenon of CCD Cameras

Smear

Smear occurs when shooting high-intensity subjects, and occurs more easily as the electronic shutter speed increases.

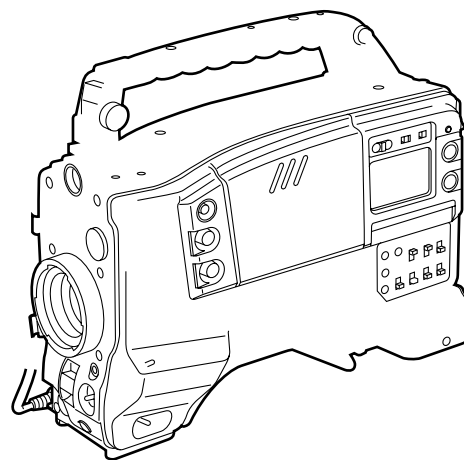

Inspections Before Shooting

Inspecting the Viewfinder

- 1** Adjust the position of the viewfinder.
- 2** Check that the color bar appears on the viewfinder screen, and then adjust the BRIGHT, CONTRAST and PEAKING controls so that the color bar appears clearly on the viewfinder.
- 3** Check the following items.
 - (1) Set the MENU SET/OFF switch to SET and check that the setting menu appears on the viewfinder screen.
 - (2) Press the PAGE button and check that the setting menu page changes.
 - (3) Press the SHIFT/ITEM switch and check that the cursor moves within the page.
 - (4) Press the UP or DOWN button to check that the setting or ON/OFF display of the item selected with the cursor changes.
- 4** Set the OUTPUT/AUTO KNEE switch to CAM and switch the FILTER knob to 1, 2, 3 and 4. Check that the number of the FILTER display on the viewfinder screen changes in accordance with the knob position.
- 5** Perform the following operations to check that the (!) lamp lights when the items set to ON at the (!) LED page are operated.
 - (1) Set the gain to any value other than 0 dB with the GAIN switch.
 - (2) Set the SHUTTER switch to ON.
 - (3) Set the WHITE BAL switch to PRST.
 - (4) Insert the lens extender.
 - (5) Set the FILTER knob to any position other than "1".
- 6** Press the SHUTTER switch repeatedly from the ON position to the SEL side and check that the shutter setting on the viewfinder screen changes.
- 7** Aim the lens at an appropriate subject and turn the focus ring to bring the subject into focus. Check the image appearing in the viewfinder.
- 8** Set both the AUDIO IN CH1 and CH2 switches to FRONT [MIC] and set LEVEL METER on the VF DISPLAY page of the setting menu to CH1. Check that the audio level appears on the viewfinder screen when sound is input from the microphone connected to the MIC IN jack on the front panel. Then, check that the audio level disappears from the viewfinder screen when LEVEL METER on the VF DISPLAY page of the setting menu is set to OFF.
- 9** Check that the zebra pattern appears on the viewfinder screen when the ZEBRA switch is set to ON, and disappears when the ZEBRA switch is set to OFF.

Note{

The items and functions in steps 3 to 6 may not be displayed or may not operate depending on the setting conditions. Set the unit to engineer mode, set DISPLAY MODE on the VF DISPLAY page of the setting menu to "3", and then set the required items at the SHUTTER SPEED, (!) LED and MENU SELECT 1/3 to 3/3 pages.

Inspecting the Iris and Zoom Functions

- 1** Set the zoom to electric zoom mode and check the electric zoom operation. Check that the image changes to telephoto and wide angle.
- 2** Set the zoom to manual zoom mode and check the manual zoom operation. Turn the manual zoom lever and check that the image changes to telephoto and wide angle.
- 3** Set the iris to automatic adjustment mode and aim the lens at subjects with differing brightness to check that the automatic iris adjustment functions.
- 4** Set the iris to manual adjustment mode and turn the iris ring to check the manual iris adjustment.
- 5** Hold down the instant iris automatic adjustment button and aim the lens at subjects with differing brightness to check the instant iris automatic adjustment performance.
- 6** Return the iris to automatic adjustment mode and change the GAIN switch setting to L, M and H to check the following items.
 - ˘ The iris is adjusted with respect to subjects with the same brightness in accordance with the switch setting.
 - ˘ The gain value display on the viewfinder screen changes in accordance with the switch setting.
- 7** When a lens with an extender is mounted, set the extender to the used position to check that the extender functions properly.

Perform “(1) Tape Running Inspections” to “(4) Earphone and Speaker Inspections” below consecutively.

Inspecting the VTR Section

(1) Tape Running Inspections

- 1** Set the VTR SAVE/STBY switch to SAVE and check that the VTR SAVE lamp inside the viewfinder lights.
- 2** Set the VTR SAVE/STBY switch to STBY and check that the VTR SAVE lamp goes off.
- 3** Set the F-RUN/R-RUN switch to R-RUN.
- 4** Set the DISPLAY switch to CTL.
- 5** Press the unit’s VTR START button and check the following items.
 - ˘ The tape reels turn.
 - ˘ The counter display number changes.
 - ˘ The REC lamp inside the viewfinder lights.
 - ˘ The RF and SERVO lamps in the display window do not light.
- 6** Press the unit’s VTR START button again. Check that the tape stops and the REC lamp inside the viewfinder goes off.
- 7** Check the same operations as in steps 5 and 6 using the VTR button of the lens.
- 8** Press the RESET button and check that the counter display number changes to “00:00:00:00”.
- 9** Set the LIGHT switch to ON and check that the display window is illuminated.
- 10** Press the REW button and then press the PLAY button after the tape has rewound for a while. Check that the recording, playback and rewind operations are performed properly.
- 11** Press the FF button and check that fast forward operation is performed properly.

Inspections Before Shooting

(2) Inspection of Audio Level Automatic Adjustment Functions

- 1 Set the AUDIO SELECT CH1/CH2 switch to AUTO.
- 2 Set the AUDIO IN CH1/CH2 switch to FRONT [MIC].
- 3 Aim a microphone connected to the MIC IN jack at an appropriate sound source and check that the level display for both CH1 and CH2 changes in accordance with the sound level.

(3) Inspection of Audio Level Manual Adjustment Functions

- 1 Set the AUDIO IN CH1/CH2 switch to FRONT [MIC].
- 2 Set the AUDIO SELECT CH1/CH2 switch to MAN.
- 3 Turn the AUDIO LEVEL CH1/CH2 controls and check that the level display increases when the controls are turned to the right.

(4) Earphone and Speaker Inspections

- 1 Set the VTR SAVE/STBY switch to STBY.
- 2 Turn the MONITOR control and check that the speaker volume changes.
- 3 Connect an earphone to the PHONES jack. Check that the sound to the speaker is cut off and that the microphone sound can be heard from the earphone.
- 4 Turn the MONITOR control and check that the earphone volume changes.

(5) Inspections when Using an External Microphone

- 1 Connect an external microphone to the AUDIO IN CH1 and CH2 connectors.
- 2 Set the AUDIO IN CH1/CH2 switch to REAR [MIC].
- 3 Aim the microphone at a sound source and check that the audio level meter in the display window and the audio level display inside the viewfinder change in accordance with the sound level. Each channel can also be checked separately by connecting a single microphone to each channel.

(6) Time Code and User Bit-Related Inspections

- 1 Set the user bit as necessary.
` See "Setting the User Bit" (page 78) for a description of setting methods.
- 2 Set the time code.
` See "Setting the Time Code" (page 77) for a description of setting methods.
- 3 Set the F-RUN/R-RUN switch to R-RUN.
- 4 Press the VTR START button.
Check that the tape runs and the counter display number changes.
- 5 Press the VTR START button again.
Check that the tape stops and the counter display number stops changing.
- 6 Set the F-RUN/R-RUN switch to F-RUN.
Check that the counter display number changes regardless of the tape running status.
- 7 Set the DISPLAY switch to UB.
Check that the set user bit is displayed.

Specifications

General

Power supply voltage:	DC 12 V
Power consumption:	29 W

Operating temperature:	32°F to 104°F
Storage temperature:	14°F to 140°F
Operating humidity:	Less than 85% (relative humidity)
Continuous operating time:	Approx. 80 min. (using 1 Anton Bauer Trimpac 14 battery)
Weight:	Approx. 14.52 lbs (6.6 kg) (incl. main unit, viewfinder, lens, battery pack, tape and microphone)
Dimensions:	4 ¹³ / ₁₆ "(W) × 8 ¹ / ₁₆ "(exclud. handle) (H) × 12 ³ / ₈ "(D) 122.5 × 204 × 313 mm

Camera Section

Pick-up devices:	2/3-inch on-chip M-FIT type of CCD
System:	RGB 3-CCD system
Picture elements:	520,000 pixel
Spectral system:	F1.4 prism system
Built-in filters:	1; 3200K 2; 5600K ○ 1/4 ND 3; 5600K 4; 5600K ○ 1/16 ND
Quantization:	10-bit A/D (R, G and B channels), 36 MHz
Digital signal processing:	16-bit long operation, 36 MHz
Horizontal drive frequency:	18.0 MHz
Programmable gains:	3 positions can be set from among 1, 3, 6, 9, 12, 15, 18, 21, 24 and 30 dB.
Super gain:	30 dB
Shutter speeds:	1/100, 1/120, 1/250, 1/500 and 1/1000 sec. Synchro scan mode; 1/63.2–1/201.9 sec.
Lens mount:	2/3" Bayonet type
Sensitivity:	F8 (2000 lux, 89.9% reflection)
Minimum subject brightness:	2 lux (F1.4, ○ 30 dB)
Image S/N ratio:	60 dB (typ.)
Horizontal resolution:	700 lines (center, typ.)
Vertical resolution:	450 lines
Sampling frequency:	36 MHz
Registration:	Below 0.05% (entire range) (exclud. lens)

Viewfinder

CRT:	1.5" monochrome
Horizontal resolution:	600 lines (center, typ.)
Controls/switches:	Controls; BRIGHT, CONTRAST, PEAKING Switches; TALLY, ZEBRA

Specifications

VTR Section

VTR Video System (during playback on a standard playback unit)

Bands:	Y; 30 Hz to 5.75 MHz ○ 1.0 dB/p 3.0 dB P _B , P _R ; 30 Hz to 2.75 MHz ○ 1.0 dB/p 3.0 dB
S/N ratio:	Better than 55 dB
K factor (2T pulse):	Within 2%
Y/C delay:	Within 20 ns

VTR Audio System (during playback on a standard playback unit)

Sampling frequency:	48 kHz (synchronized to video)
Quantization:	16-bits/sample
Frequency response:	20 Hz to 20 kHz ± 1.0 dB (at the reference level on MIC LOWCUT OFF status of the Setting Menu)
Dynamic range:	85 dB or more (at 1 kHz, AWTD)
Distortion:	Within 0.1% (at 1 kHz, reference level)
Wow/flutter:	Below measurable limit
Head room:	20 dB
Emphasis:	T1r 50 fls, T2r 15 fls (can be turned ON/OFF)

VTR Tape Running System

Tape used:	DVCPRO format 1/4-inch M-size cassette tape
Tape speed:	67.640 mm/s (50 Mbps) 33.820 mm/s (25 Mbps)
Recording/playback time:	Approx. 33 min. (50 Mbps, using the AJ-P66MP) Approx. 66 min. (25 Mbps, using the AJ-P66MP)
FF/REW time:	Approx. 3 min. (using the AJ-P66MP)

Connectors

Input

AUDIO IN CH1/CH2

(XLR • 2, 3-pin, female): MIC/LINE switchable, balanced, more than 10 kohm
MIC; Menu setting to p 60/p 50/p 40 dBu,
LINE; Menu setting to p 6/0/○ 4 dBu

MIC IN (XLR, 3-pin, female): Phantom ○ 48 V, p 60 dB, balanced, 3 kohm
Menu setting to p 60/p 50/p 40 dBu

GENLOCK IN (BNC)

TIME CODE IN (BNC): 1.0 Vp-p, 75 ohm
0.5 to 18 Vp-p, high-impedance

Output

CAMERA OUT (BNC): 1.0 Vp-p, 75 ohm

VIDEO OUT (BNC): 1.0 Vp-p, 75 ohm

AUDIO OUT (CH1/CH2/MIX)

(XLR, 3-pin, male): ○ 4 dBu, balanced, low-impedance
(CH1, CH2 or MIX selectable)

AUDIO CH1/CH2 OUT
(12-pin, multi connector)

(option): p 20 dBu, unbalanced, low-impedance

TIME CODE OUT (BNC): 1.5 Vp-p, low-impedance

PHONES (mini-jack • 2):

Other

DC IN (XLR, 4-pin, male): DC 11–17 V

DC OUT (4-pin): DC 11–17 V, maximum rated current; 0.1 A

LENS (12-pin):

REMOTE (ECU, 6-pin):

Accessories

- Shoulder belt (1)
- Sony battery connector (screws included)

Weight and dimensions shown are approximate.
Specifications are subject to change without notice.

Related Components

Power supply related

AU-BP220, AU-BP402 battery packs
AG-B425 battery charger (for charging the AU-BP220 and AU-BP402 battery packs)
AU-M402H battery case
AJ-B75 AC adaptor

Viewfinder

5-inch viewfinder

External VTR-related

Portable video cassette recorder
AJ-YA710P time code input/output/video input adaptor
AJ-YA900P 26-pin/12-pin output connector
AQ-EC1 extension control unit
Connection cables
` for connecting an external VTR to the 26-pin interface
` for connecting an external VTR to the 14-pin/26-pin interface
` SHAN-C12TCA multi connector cable

Audio components

AJ-MC700P microphone kit
Stereo microphone
AJ-MH700P microphone holder
WX-RA700 wireless receiver
WX-R980 camera attachment

Maintenance products

AJ-CL12MP cleaning tape
AJ-SC900 soft carrying case
AJ-HT900 carrying case
SHAN-RC700 rain cover

Panasonic

Broadcast & Television Systems Company

Division of Matsushita Electric Corporation of America

Executive Office

One Panasonic Way (4B-7), Secaucus, NJ 07094

Service Centers

Eastern: One Panasonic Way, Panazip (2A-4), Secaucus, NJ 07094

(201)-348-7677 Fax (201)-348-7511

Southern: 1225 Northbrook Parkway, Suite #170, Suwanee, GA 30174

(770)-338-6855 Fax (770)-338-6656

Western: 4001 West Alameda Ave., Suite 100, Burbank, CA 91505

(818)-562-1579 Fax (818)-562-6663

Parts Information & Ordering

9:00 am–5:00 pm (EST) (800)-334-4881/24 hr. Fax (800)-334-4880

Technical Support

Emergency 24 hr. Parts & Support (800)-222-0741

Training Information

Digital System Products (201)-392-6076

Service Literature

(201)-392-6281

Panasonic Canada Inc.

5770 Ambler Drive, Mississauga, Ontario L4W 2T3 (905)-624-5010

Panasonic de Mexico S.A. de C.V.

Av angel Urraza Num. 1209 Col. de Valle 03100 Mexico, D.F. (52) 1 951 2127

Printed in Japan

VQT7347-1

F0398H10998 

